

BOATING

*On The
Hudson
& Beyond*

JUNE 2018

Dock & Dine



A NEW ERA

★ CLARK'S STEAKHOUSE
& SCHUYLER YACHT BASIN ★

Alex's Marine
Plus!

FRIEND US ON FACEBOOK 

Route 9W, New Windsor, NY
Factory Certified • Fully Insured

TO CONTACT ALEX:
P: 845.565.9199
E: ALEXSMARINE@AOL.COM
W: ALEXSMARINEPLUS.COM

DON'T LEAVE THE DOCK WITHOUT THE NEW ARM IT SENSOR SYSTEM! IT TAKES THE WORRIES OUT OF BOATING!

WE ARE HERE TO HELP!

DOCKSIDE SERVICE AVAILABLE | BOATS/RV'S/PWC'S/ATV'S
GREAT PRICES! | EXCEPTIONAL WORK! | 34 YEARS EXPERIENCE

TUNE UPS | RE-POWERS | ELECTRONICS | HAULING | MAINTENANCE | LICENSED & INSURED

UNIQUE MARINE

(845) 489-4524
uniquemarineny.com
24 Olympic Way, Poughkeepsie, NY 12603

UNIQUE MARINE NEW YORKS WINTERIZATION HEADQUARTERS

WINTERIZATION EXPERTS LOCATED CONVENIENTLY ON RT 44 IN POUGHKEEPSIE. UNIQUE MARINE IS AN EASY RIDE FROM ALL SURROUNDING TOWNS.

UNIQUE MARINE WINTERIZES BOATS OF ALL MAKES, MODELS, SIZES, AND YEARS! GUARANTEED FREEZE PROOF! WE CAN ALSO HAUL ALL SIZES TO 38FT ON OUR STATE OF THE ART HYDRAULIC AIR RIDE TRAILER.

OUR SHRINK WRAPPING SERVICES ARE HIGH QUALITY, DONE RIGHT AND GUARANTEED TOUGH!
CONTACT UNIQUE MARINE TODAY TO SCHEDULE YOUR APPOINTMENTS.

WE SELL ALL WINTERIZATION & SHRINK WRAP SUPPLIES!

BOATING

On The Hudson & Beyond®

June

2018

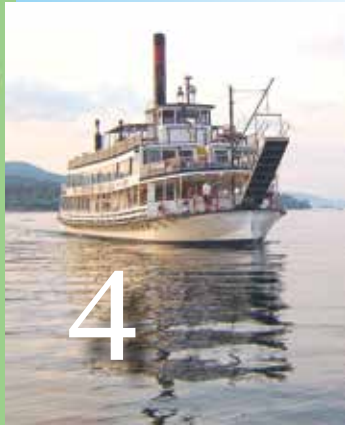
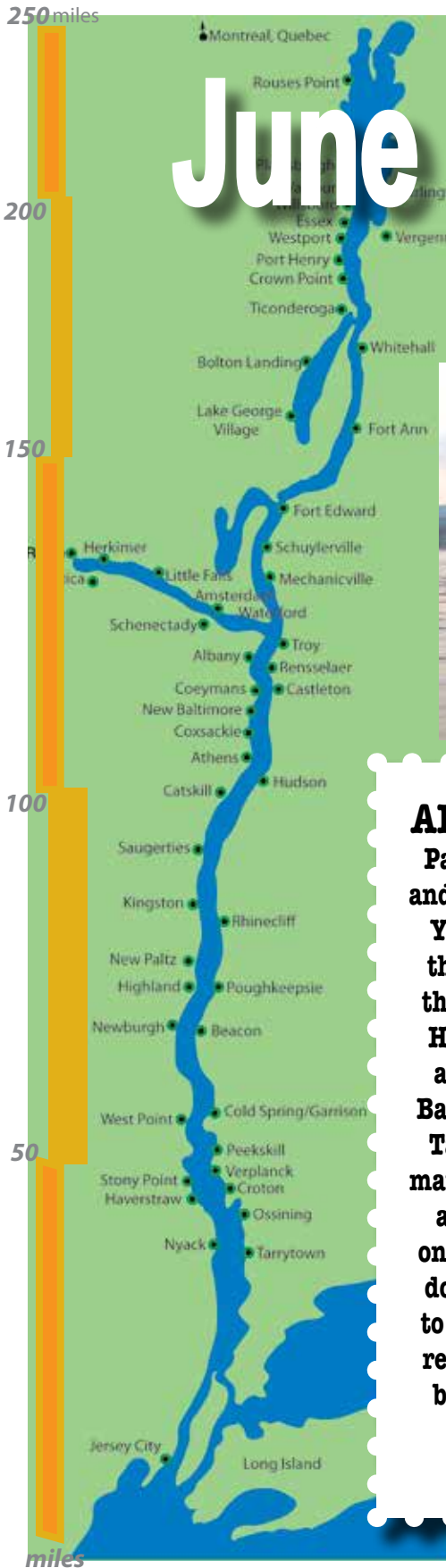

ABOUT the COVER

Passing the Baton! Phil and Judy Dean with Jason Young, sitting opposite them having a drink on the all new Clarks Steak House Restaurant deck at Schuylerville Yacht Basin, Schuylerville, NY. Talk about upgrading a marina, Jason has created a fantastic restaurant only steps away from the docks. The best of Luck to Phil and Judy in their retirement and the very best to Jason Young in his ownership of an iconic marina.

4 • Fun Music!

12 • "Give Back"

16 • Pure Joy!

19 • Eels - from the Sargasso Sea

38 • Sports Clubs and the River

23

Fueling the Boat & Feeding the Crew

44 • Fly a Flying Boxcar

51 • Planning an Upstate Trip?

Every Month

9 • Tides

40 • Ask Alex

42 • Cathy Karas

54 • Ask Dr. Gel

60 • Service Directory

66 • Classifieds

FUN MUSIC!

by Matthew
Dow

Photos by
Marilynn Buehler

Anthony Benedetto at the keyboard, circa 2015.



For the last four decades, the melodic strains of the MINNE HA-HA's steam calliopo have wafted over the Village of Lake George. From Memorial Day through Columbus Day, its clarion call can be heard six to seven times each day, so much so that some locals even use it as a way to keep time during the busy season. The calliopo has become an integral part of the fabric of the community, and its humble beginnings can be traced back to a small village not far from our own.

In 1855, a farmer named Joshua C. Stoddard, of Worcester, VT, invented a peculiar instrument consisting of several graduated steam whistles with corresponding valves sitting atop a long pipe, or manifold. These valves were connected with a system of levers and wires to a small keyboard. Pressing a key would pull these wires and levers, opening the valve and allowing steam to flow from the pipe into the whistle. On October 9th of that year, the patent for his "American Patented Steam Piano" was approved. Stoddard had built the instrument not for use aboard a



Calliope in action.

boat, but rather as a replacement for the bells in the tower of his local church. During that first Vermont winter, his "Steam Piano" had many issues. Not only was the volume too much for the other parishioners, but the pipes were not insulated. Many ended up bursting, rendering the instrument inoperable. A defeated Stoddard removed the instrument from the steeple, and placed it in a barn on his property. While this could have very well been the end of this unique piece of machinery, fate intervened. Stoddard's brother was a steamboat captain on the Hudson River in New York. At that time, companies were pondering ways to attract more business. The story goes that he remembered his brother's invention, and asked Joshua if he could place it aboard the boat he was in command of. He agreed, and rest is history! While the instrument became commonplace on excursion boats and showboats alike, they also had a strong reputation in the circus world. In the late 1850's, circus magnet P.T. Barnum acquired a "patented Steam Piano" to include in his circus parade.

In 1973, the Lake George Steamboat Company founded its southern sister company, the New Orleans Steamboat Company, and embarked on a journey to build a magnificent sternwheel steamboat to run excursion trips in the New Orleans. Since the calliope had strong ties to the Inland Rivers, and especially excursion vessels, it was decided to have an instrument constructed for the new boat. Owners Wilbur E. Dow Jr. and Bill Dow contracted the Frisbie Engine and Machine Company of Cincinnati, OH, to build two calliopes for them. One was to go to the new build in Louisiana,

which would eventually be the Str. NATCHEZ, and the other would go to the MINNE-HA-HA, or the "MINNE" as she is affectionately called. Cincinnati was no stranger to the instrument. Not only had numerous riverboats played their calliopes while visiting the city, but two major calliope builders had been located there! The first was Thomas J. Nichol who, in the early 1900's, built what some believe to be the best sounding steam calliopes ever produced. The second was Ernest J. Wilde, who built several instruments in the 1950's and 1960's. While the Frisbie Company had never built a calliope before, they had been in business since 1874, and were renowned for their steam engines and pumps. Jess Coen, the owner of the company at the time, took drawings and measurements from both Nichol and Wilde calliopes, and fused the two designs together. What he produced was, arguably, one of the finest examples of the instrument ever crafted: 32 graduated brass steam whistles, electronically-operated solenoid valves for ease of use, and corresponding lightbulbs that lit up the steam at night, creating something akin to the Northern Lights and known as the "Aurora Effect". By early summer 1974, the first instrument was completed. It was shipped up to Lake George and installed aboard the "MINNE", where it was played for the first time on July 2nd of that year.

For almost 20 years, the Frisbie instrument was played aboard the "MINNE". The calliope sat directly in front of the pilothouse, and the keyboard was located inside the pilothouse and underneath the forward port-side window. While not much exists in the way of pictures or recordings of this calliope, the boat's calliope player, Marilyn Buehler, had a couple good close-up shots of it in action, one of which is included in this article. By the time 1992 rolled around, the calliope was in need of some TLC. The instrument was sent out to a company in Iowa for refurbishment, and in the meantime, a smaller calliope was placed onboard. Through a series of unfortunate events over the course of

**The “American Patented
Steam Piano” unique
American Steam Age
Musical Instrument**



the following year, the Frisbie calliope was sold to a gaming boat in Natchez, MS, where it was put on display on the top deck of the boat. After a short time, the whistles were removed, placed in storage, and then lost in time. To this day, they have not been found. The calliope that had been placed on the “MINNE” as a ‘temp’ became her permanent instrument. This calliope had been built by Ernest J. Wilde in the early 1960’s, and had been aboard a party boat in the Cincinnati harbor. Strangely enough, it is believed that this was one of the instruments Jess Coen used for measurements to make his calliopes in the 1970’s! The construction of these whistles were different from the Frisbie. Wilde’s whistles were long and slender, and looked almost like an assembly of mortar shells. Other instruments of his were placed aboard the ELIZABETH LOUISE of Sacramento, CA and the BELLE OF LOUISVILLE of Louisville, KY. With the change in instrument, the location of it was changed as well. Instead of sitting in front of the pilothouse as the Frisbie had, the Wilde calliope was moved forward of the port smokestack. The manifold was shorter, and could fit in the space better. This also increased the visibility of the instrument, allowing for an unobstructed view of the calliope from the pier below for the first time. In the summer of 2004, yours truly played his first song on the Wilde, igniting a love for the calliope and its operation. It had not been taken care of in some time, and needed some work. I made it my mission to make it a showpiece again. While some brass polish and a fresh coat of paint made it look better, there was only so much that could be done to get it back in prime

operational shape. I had no knowledge about valve maintenance, tuning or electrical work other than what I had plucked from the minds of our engineers. By the end of the 2010 season, the calliope had fallen into an abysmal state. It got to the point where we were getting more complaints about its sound than we were compliments! The time had come to find a new calliope for the boat. Around that time, I became friends with Dave Morecraft, of Peru, IN. Dave’s family had been building metal furniture in town for decades, which had given him an immense knowledge of machining and engineering. Peru itself had also long been a famous circus town, known for its immense shows and parades, complete with calliope wagons. He fell in love with the instrument, and got it in his mind to build them. He used measurements off an old Thomas J. Nichol circus calliope in town, which he affectionately referred to as “Grandpa”, and had built instruments for a number of steamboats, most notably a replacement calliope for the BELLE OF LOUISVILLE and a new instrument for grand overnight steamboat AMERICAN QUEEN. Like Nichol before him, his whistles were constructed with a mixture of brass and copper, giving his instruments a deep, smooth tonal quality, unlike the brassy shrillness of the Frisbie and Wilde calliopes. I went out to Peru and played his personal instrument in the summer of 2010. From that first chord, I knew a Morecraft calliope is what the MINNE needed. Armed with a sample whistle and several videos, I went back home and convinced my Dad and our engineers to give the green light for a new calliope.

By the spring of 2012, the instrument was ready to go. The "MINNE" usually begins her season Memorial Day weekend, and I was determined to have the new calliope playing by then. The week leading up to Memorial Day was our targeted installation date, and what a busy week it was! With the help of friends and fellow calliopists Anthony Benedetto and Zach Morecraft, and our talented welder Henk Overbeek, we pulled the old instrument off and installed the new calliope just in time, getting steam up and doing final testing just the day before! That first weekend was a fun one, filled with live performances by all of us, each more ecstatic than the last to "pluck the plastics". We got a really special treat on Sunday when Marilyn Buehler, the boat's calliope player when the Frisbie was aboard, came down and played a rousing Patriotic Medley. For a lot of the older crew members onboard, listening to her play again brought back a lot of good memories.

Over the next couple of years, some changes were made to the calliope and its operation. In 2013, we got a new keyboard with the ability to be placed

P.T. Barnum, being the showman he was, figured that a catchier name was needed for it. He decided on the name of the Greek muse of music and epic poetry for his instrument, and from then on, the "American Patented Steam Piano" was known simply as the 'Calliope'.

out on the instrument. For the first time ever on the "MINNE", a person could play outside and been seen playing, rather than being hidden in the pilothouse. A better sounding instrument and this new keyboard allowed us to start playing underway, giving a enjoyable show to those aboard and those on the shoreline as we passed the hotels on the lakefront. Next, a new pressure regulator was installed, helping the pressure and volume issues we had with the slightly larger Morecraft calliope. Dave imparted a lot of knowledge on us about valve maintenance, whistle care, and winter storage, which helped with the overall operation of the instrument. Our good friend and phenomenal calliope player, Travis C. Vasconcelos, recorded several new medleys for the player unit, which is used when there is not a person available to play live. One of the most requested is his "Phantom of the Opera" medley. In September 2013, we recorded the "MINNE's" first Calliope CD, with songs played by Travis, Anthony Benedetto, and your truly. Between 2015 and 2016, Travis and James Hall, his good friend and electrician extraordinaire, came to Lake George to replace long sections of wire and install a new player unit, replacing the 1993-era floppy disk drive that had been used since the Wilde had been installed.

At the time of this writing, the "MINNE" and her calliope are being prepared for the 2018 sailing season. Soon, the sweet sounds of steam will again echo through the mountain valley, and the dulcet tones of the calliope will bring joy to thousands in a community that has grown fond of its hometown steamboat and her unique American instrument.

SAIL LAKE GEORGE

LAC du SAINT SACREMENT

LUNCHEON & DINNER CRUISES
Live Entertainment & Narration

LAKE GEORGE STEAMBOAT CO.
57 BEACH ROAD, LAKE GEORGE VILLAGE
Information and Reservations: 668-5777, ext. 4
www.lakegeorgesteamboat.com

The Battery

1	FR	5:08 am L	11:15 am H	5:07 pm L	11:15 pm H
2	SA	5:47 am L	12:03 pm H	5:44 pm L	11:58 pm H
3	SU	6:28 am L	12:49 pm H	6:21 pm L	
4	MO	12:42 am H	7:11 am L	1:33 pm H	7:06 pm L
5	TU	1:24 am H	7:59 am L	2:15 pm H	8:11 pm L
6	WE	2:07 am H	8:53 am L	2:56 pm H	9:21 pm L
7	TH	2:53 am H	9:47 am L	3:40 pm H	10:22 pm L
8	FR	3:46 am H	10:36 am L	4:28 pm H	11:17 pm L
9	SA	4:44 am H	11:23 am L	5:20 pm H	
10	SU	12:09 am L	5:45 am H	12:11 pm L	6:11 pm H
11	MO	1:00 am L	6:42 am H	12:59 pm L	7:00 pm H
12	TU	1:52 am L	7:35 am H	1:50 pm L	7:48 pm H
13	WE	2:44 am L	8:26 am H	2:42 pm L	8:36 pm H
14	TH	3:35 am L	9:18 am H	3:34 pm L	9:27 pm H
15	FR	4:25 am L	10:15 am H	4:26 pm L	10:23 pm H
16	SA	5:16 am L	11:15 am H	5:19 pm L	11:23 pm H
17	SU	6:08 am L	12:17 pm H	6:15 pm L	
18	MO	12:26 am H	7:03 am L	1:16 pm H	7:16 pm L
19	TU	1:26 am H	8:01 am L	2:13 pm H	8:22 pm L
20	WE	2:23 am H	9:01 am L	3:09 pm H	9:29 pm L
21	TH	3:21 am H	9:59 am L	4:06 pm H	10:30 pm L
22	FR	4:20 am H	10:52 am L	5:02 pm H	11:27 pm L
23	SA	5:20 am H	11:41 am L	5:56 pm H	
24	SU	12:19 am L	6:18 am H	12:29 pm L	6:46 pm H
25	MO	1:08 am L	7:09 am H	1:14 pm L	7:31 pm H
26	TU	1:55 am L	7:56 am H	1:59 pm L	8:12 pm H
27	WE	2:40 am L	8:39 am H	2:43 pm L	8:51 pm H
28	TH	3:23 am L	9:22 am H	3:25 pm L	9:29 pm H
29	FR	4:04 am L	10:04 am H	4:05 pm L	10:08 pm H
30	SA	4:43 am L	10:48 am H	4:43 pm L	10:47 pm H

TIDES June

Spuyten Duyvil

1	FR	5:56 am L	12:07 pm H	5:55 pm L	
2	SA	12:07 am H	6:35 am L	12:55 pm H	6:32 pm L
3	SU	12:50 am H	7:16 am L	1:41 pm H	7:09 pm L
4	MO	1:34 am H	7:59 am L	2:25 pm H	7:54 pm L
5	TU	2:16 am H	8:47 am L	3:07 pm H	8:59 pm L
6	WE	2:59 am H	9:41 am L	3:48 pm H	10:09 pm L
7	TH	3:45 am H	10:35 am L	4:32 pm H	11:10 pm L
8	FR	4:38 am H	11:24 am L	5:20 pm H	
9	SA	12:05 am L	5:36 am H	12:11 pm L	6:12 pm H
10	SU	12:57 am L	6:37 am H	12:59 pm L	7:03 pm H
11	MO	1:48 am L	7:34 am H	1:47 pm L	7:52 pm H
12	TU	2:40 am L	8:27 am H	2:38 pm L	8:40 pm H
13	WE	3:32 am L	9:18 am H	3:30 pm L	9:28 pm H
14	TH	4:23 am L	10:10 am H	4:22 pm L	10:19 pm H
15	FR	5:13 am L	11:07 am H	5:14 pm L	11:15 pm H
16	SA	6:07 am L	12:07 pm H	6:07 pm L	
17	SU	12:15 am H	6:56 am L	1:09 pm H	7:03 pm L
18	MO	1:18 am H	7:51 am L	2:08 pm H	8:04 pm L
19	TU	2:18 am H	8:49 am L	3:05 pm H	9:10 pm L
20	WE	3:15 am H	9:49 am L	4:01 pm H	10:17 pm L
21	TH	4:13 am H	10:47 am L	4:58 pm H	11:18 pm L
22	FR	5:12 am H	11:40 am L	5:54 pm H	
23	SA	12:15 am L	6:12 am H	12:29 pm L	6:48 pm H
24	SU	1:07 am L	7:10 am H	1:17 pm L	7:38 pm H
25	MO	1:56 am L	8:01 am H	2:02 pm L	8:23 pm H
26	TU	2:43 am L	8:48 am H	2:47 pm L	9:04 pm H
27	WE	3:28 am L	9:31 am H	3:31 pm L	9:43 pm H
28	TH	4:11 am L	10:14 am H	4:13 pm L	10:21 pm H
29	FR	4:52 am L	10:56 am H	4:53 pm L	11:00 pm H
30	SA	5:31 am L	11:40 am H	5:31 pm L	11:39 pm H

Your local on-water assistance experts.

\$179
a year

800-4-SEATOW
seatow.com

49¢
a day!

Tarrytown

1	FR	12:22 am H	7:05 am L	1:04 pm H	7:04 pm L
2	SA	1:04 am H	7:44 am L	1:52 pm H	7:41 pm L
3	SU	1:47 am H	8:25 am L	2:38 pm H	8:18 pm L
4	MO	2:31 am H	9:08 am L	3:22 pm H	9:03 pm L
5	TU	3:13 am H	9:56 am L	4:04 pm H	10:08 pm L
6	WE	3:56 am H	10:50 am L	4:45 pm H	11:18 pm L
7	TH	4:42 am H	11:44 am L	5:29 pm H	
8	FR	12:19 am L	5:35 am H	12:33 pm L	6:17 pm H
9	SA	1:14 am L	6:33 am H	1:20 pm L	7:09 pm H
10	SU	2:06 am L	7:34 am H	2:08 pm L	8:00 pm H
11	MO	2:57 am L	8:31 am H	2:56 pm L	8:49 pm H
12	TU	3:49 am L	9:24 am H	3:47 pm L	9:37 pm H
13	WE	4:41 am L	10:15 am H	4:39 pm L	10:25 pm H
14	TH	5:32 am L	11:07 am H	5:31 pm L	11:16 pm H
15	FR	6:22 am L	12:04 pm H	6:23 pm L	
16	SA	12:12 am H	7:13 am L	1:04 pm H	7:16 pm L
17	SU	1:12 am H	8:05 am L	2:06 pm H	8:12 pm L
18	MO	2:15 am H	9:00 am L	3:05 pm H	9:13 pm L
19	TU	3:15 am H	9:58 am L	4:02 pm H	10:19 pm L
20	WE	4:12 am H	10:58 am L	4:58 pm H	11:26 pm L
21	TH	5:10 am H	11:56 am L	5:55 pm H	
22	FR	12:27 am L	6:09 am H	12:49 pm L	6:51 pm H
23	SA	1:24 am L	7:09 am H	1:38 pm L	7:45 pm H
24	SU	2:16 am L	8:07 am H	2:26 pm L	8:35 pm H
25	MO	3:05 am L	8:58 am H	3:11 pm L	9:20 pm H
26	TU	3:52 am L	9:45 am H	3:56 pm L	10:01 pm H
27	WE	4:37 am L	10:28 am H	4:40 pm L	10:40 pm H
28	TH	5:20 am L	11:11 am H	5:22 pm L	11:18 pm H
29	FR	6:01 am L	11:53 am H	6:02 pm L	11:57 pm H
30	SA	6:40 am L	12:37 pm H	6:40 pm L	

TIDES June

Haverstraw

1	FR	12:56 am H	7:58 am L	1:35 pm H	7:37 pm L
2	SA	1:33 am H	8:39 am L	2:22 pm H	8:14 pm L
3	SU	2:14 am H	9:21 am L	3:13 pm H	8:57 pm L
4	MO	3:00 am H	10:05 am L	4:03 pm H	9:49 pm L
5	TU	3:49 am H	10:53 am L	4:50 pm H	10:52 pm L
6	WE	4:38 am H	11:42 am L	5:37 pm H	
7	TH	12:00 am L	5:29 am H	12:32 pm L	6:25 pm H
8	FR	1:06 am L	6:24 am H	1:21 pm L	7:15 pm H
9	SA	2:05 am L	7:23 am H	2:0 pm L	8:04 pm H
10	SU	2:59 am L	8:19 am H	2:50 pm L	8:50 pm H
11	MO	3:51 am L	9:11 am H	3:35 pm L	9:35 pm H
12	TU	4:43 am L	10:00 am H	4:23 pm L	10:19 pm H
13	WE	5:35 am L	10:50 am H	5:14 pm L	11:06 pm H
14	TH	6:26 am L	11:41 am H	6:08 pm L	11:55 pm H
15	FR	7:17 am L	12:35 pm H	7:02 pm L	
16	SA	12:47 am H	8:07 am L	1:33 pm H	7:56 pm L
17	SU	1:44 am H	9:00 am L	2:36 pm H	8:55 pm L
18	MO	2:45 am H	9:56 am L	3:40 pm H	9:58 pm L
19	TU	3:49 am H	10:53 am L	4:41 pm H	11:05 pm L
20	WE	4:50 am H	11:50 am L	5:40 pm H	
21	TH	12:11 am L	5:50 am H	12:46 pm L	6:39 pm H
22	FR	1:16 am L	6:51 am H	1:39 pm L	7:38 pm H
23	SA	2:15 am L	7:51 am H	2:28 pm L	8:32 pm H
24	SU	3:09 am L	8:46 am H	3:13 pm L	9:20 pm H
25	MO	4:00 am L	9:36 am H	3:56 pm L	10:04 pm H
26	TU	4:48 am L	10:22 am H	4:38 pm L	10:44 pm H
27	WE	5:34 am L	11:06 am H	5:20 pm L	11:21 pm H
28	TH	6:17 am L	11:49 am H	6:00 pm L	11:57 pm H
29	FR	6:57 am L	12:30 pm H	6:39 pm L	
30	SA	12:32 am H	7:35 am L	1:12 pm H	7:17 pm L

Peekskill

1	FR	1:01 am H	8:11 am L	1:43 pm H	8:10 pm L
2	SA	1:43 am H	8:50 am L	2:31 pm H	8:47 pm L
3	SU	2:26 am H	9:31 am L	3:17 pm H	9:24 pm L
4	MO	3:10 am H	10:14 am L	4:01 pm H	10:09 pm L
5	TU	3:52 am H	11:02 am L	4:43 pm H	11:14 pm L
6	WE	4:35 am H	11:56 am L	5:24 pm H	pm L
7	TH	12:24 am L	5:21 am H	12:50 pm L	6:08 pm H
8	FR	1:25 am L	6:14 am H	1:39 pm L	6:56 pm H
9	SA	2:20 am L	7:12 am H	2:26 pm L	7:48 pm H
10	SU	3:12 am L	8:13 am H	3:14 pm L	8:39 pm H
11	MO	4:03 am L	9:10 am H	4:02 pm L	9:28 pm H
12	TU	4:55 am L	10:03 am H	4:53 pm L	10:16 pm H
13	WE	5:47 am L	10:54 am H	5:45 pm L	11:04 pm H
14	TH	6:38 am L	11:46 am H	6:37 pm L	11:55 pm H
15	FR	7:28 am L	12:43 pm H	7:29 pm L	pm H
16	SA	12:51 am H	8:19 am L	1:43 pm H	8:22 pm L
17	SU	1:51 am H	9:11 am L	2:45 pm H	9:18 pm L
18	MO	2:54 am H	10:06 am L	3:44 pm H	10:19 pm L
19	TU	3:54 am H	11:04 am L	4:41 pm H	11:25 pm L
20	WE	4:51 am H	12:04 pm L	5:37 pm H	pm L
21	TH	12:32 am L	5:49 am H	1:02 pm L	6:34 pm H
22	FR	1:33 am L	6:48 am H	1:55 pm L	7:30 pm H
23	SA	2:30 am L	7:48 am H	2:44 pm L	8:24 pm H
24	SU	3:22 am L	8:46 am H	3:32 pm L	9:14 pm H
25	MO	4:11 am L	9:37 am H	4:17 pm L	9:59 pm H
26	TU	4:58 am L	10:24 am H	5:02 pm L	10:40 pm H
27	WE	5:43 am L	11:07 am H	5:46 pm L	11:19 pm H
28	TH	6:26 am L	11:50 am H	6:28 pm L	11:57 pm H
29	FR	7:07 am L	12:32 pm H	7:08 pm L	pm H
30	SA	12:36 am H	7:46 am L	1:16 pm H	7:46 pm L

Newburgh

1	FR	2:19 am H	9:11 am L	3:01 pm H	9:10 pm L
2	SA	3:01 am H	9:50 am L	3:49 pm H	9:47 pm L
3	SU	3:44 am H	10:31 am L	4:35 pm H	10:24 pm L
4	MO	4:28 am H	11:14 am L	5:19 pm H	11:09 pm L
5	TU	5:10 am H	12:02 pm L	6:01 pm H	pm H
6	WE	12:14 am L	5:53 am H	12:56 pm L	6:42 pm H
7	TH	1:24 am L	6:39 am H	1:50 pm L	7:26 pm H
8	FR	2:25 am L	7:32 am H	2:39 pm L	8:14 pm H
9	SA	3:20 am L	8:30 am H	3:26 pm L	9:06 pm H
10	SU	4:12 am L	9:31 am H	4:14 pm L	9:57 pm H
11	MO	5:03 am L	10:28 am H	5:02 pm L	10:46 pm H
12	TU	5:55 am L	11:21 am H	5:53 pm L	11:34 pm H
13	WE	6:47 am L	12:12 pm H	6:45 pm L	pm L
14	TH	12:22 am H	7:38 am L	1:04 pm H	7:37 pm L
15	FR	1:13 am H	8:28 am L	2:01 pm H	8:29 pm L
16	SA	2:09 am H	9:19 am L	3:01 pm H	9:22 pm L
17	SU	3:09 am H	10:11 am L	4:03 pm H	10:18 pm L
18	MO	4:12 am H	11:06 am L	5:02 pm H	11:19 pm L
19	TU	5:12 am H	12:04 pm L	5:59 pm H	pm H
20	WE	12:25 am L	6:09 am H	1:04 pm L	6:55 pm H
21	TH	1:32 am L	7:07 am H	2:02 pm L	7:52 pm H
22	FR	2:33 am L	8:06 am H	2:55 pm L	8:48 pm H
23	SA	3:30 am L	9:06 am H	3:44 pm L	9:42 pm H
24	SU	4:22 am L	10:04 am H	4:32 pm L	10:32 pm H
25	MO	5:11 am L	10:55 am H	5:17 pm L	11:17 pm H
26	TU	5:58 am L	11:42 am H	6:02 pm L	11:58 pm H
27	WE	6:43 am L	12:25 pm H	6:46 pm L	pm L
28	TH	12:37 am H	7:26 am L	1:08 pm H	7:28 pm L
29	FR	1:15 am H	8:07 am L	1:50 pm H	8:08 pm L
30	SA	1:54 am H	8:46 am L	2:34 pm H	8:46 pm L

TIDES June



Disentanglements



Re-Fueling



Jump Starts



Towing

Poughkeepsie

1	FR	3:07 am H	9:54 am L	3:49 pm H	9:53 pm L
2	SA	3:49 am H	10:33 am L	4:37 pm H	10:30 pm L
3	SU	4:32 am H	11:14 am L	5:23 pm H	11:07 pm L
4	MO	5:16 am H	11:57 am L	6:07 pm H	11:52 pm L
5	TU	5:58 am H	12:45 pm L	6:49 pm H	pm H
6	WE	12:57 am L	6:41 am H	1:39 pm L	7:30 pm H
7	TH	2:07 am L	7:27 am H	2:33 pm L	8:14 pm H
8	FR	3:08 am L	8:20 am H	3:22 pm L	9:02 pm H
9	SA	4:03 am L	9:18 am H	4:09 pm L	9:54 pm H
10	SU	4:55 am L	10:19 am H	4:57 pm L	10:45 pm H
11	MO	5:46 am L	11:16 am H	5:45 pm L	11:34 pm H
12	TU	6:38 am L	12:09 pm H	6:36 pm L	pm L
13	WE	12:22 am H	7:30 am L	1:00 pm H	7:28 pm L
14	TH	1:10 am H	8:21 am L	1:52 pm H	8:20 pm L
15	FR	2:01 am H	9:11 am L	2:49 pm H	9:12 pm L
16	SA	2:57 am H	10:02 am L	3:49 pm H	10:05 pm L
17	SU	3:57 am H	10:54 am L	4:51 pm H	11:01 pm L
18	MO	5:00 am H	11:49 am L	5:50 pm H	pm H
19	TU	12:02 am L	6:00 am H	12:47 pm L	6:47 pm H
20	WE	1:08 am L	6:57 am H	1:47 pm L	7:43 pm H
21	TH	2:15 am L	7:55 am H	2:45 pm L	8:40 pm H
22	FR	3:16 am L	8:54 am H	3:38 pm L	9:36 pm H
23	SA	4:13 am L	9:54 am H	4:27 pm L	10:30 pm H
24	SU	5:05 am L	10:52 am H	5:15 pm L	11:20 pm H
25	MO	5:54 am L	11:43 am H	6:00 pm L	pm L
26	TU	12:05 am H	6:41 am L	12:30 pm H	6:45 pm L
27	WE	12:46 am H	7:26 am L	1:13 pm H	7:29 pm L
28	TH	1:25 am H	8:09 am L	1:56 pm H	8:11 pm L
29	FR	2:03 am H	8:50 am L	2:38 pm H	8:51 pm L
30	SA	2:42 am H	9:29 am L	3:22 pm H	9:29 pm L

TIDES June

Kingston

1	FR	3:53 am H	10:42 am L	4:35 pm H	10:41 pm L
2	SA	4:35 am H	11:21 am L	5:23 pm H	11:18 pm L
3	SU	5:18 am H	12:02 pm L	6:09 pm H	11:55 pm L
4	MO	6:02 am H	12:45 pm L	6:53 pm H	pm H
5	TU	12:40 am L	6:44 am H	1:33 pm L	7:35 pm H
6	WE	1:45 am L	7:27 am H	2:27 pm L	8:16 pm H
7	TH	2:55 am L	8:13 am H	3:21 pm L	9:00 pm H
8	FR	3:56 am L	9:06 am H	4:10 pm L	9:48 pm H
9	SA	4:51 am L	10:04 am H	4:57 pm L	10:40 pm H
10	SU	5:43 am L	11:05 am H	5:45 pm L	11:31 pm H
11	MO	6:34 am L	12:02 pm H	6:33 pm L	pm L
12	TU	12:20 am H	7:26 am L	12:55 pm H	7:24 pm L
13	WE	1:08 am H	8:18 am L	1:46 pm H	8:16 pm L
14	TH	1:56 am H	9:09 am L	2:38 pm H	9:08 pm L
15	FR	2:47 am H	9:59 am L	3:35 pm H	1:00 pm L
16	SA	3:43 am H	10:50 am L	4:35 pm H	10:53 pm L
17	SU	4:43 am H	11:42 am L	5:37 pm H	11:49 pm L
18	MO	5:46 am H	12:37 pm L	6:36 pm H	pm H
19	TU	12:50 am L	6:46 am H	1:35 pm L	7:33 pm H
20	WE	1:56 am L	7:43 am H	2:35 pm L	8:29 pm H
21	TH	3:03 am L	8:41 am H	3:33 pm L	9:26 pm H
22	FR	4:04 am L	9:40 am H	4:26 pm L	10:22 pm H
23	SA	5:01 am L	10:40 am H	5:15 pm L	11:16 pm H
24	SU	5:53 am L	11:38 am H	6:03 pm L	pm L
25	MO	12:06 am H	6:42 am L	12:29 pm H	6:48 pm L
26	TU	12:51 am H	7:29 am L	1:16 pm H	7:33 pm L
27	WE	1:32 am H	8:14 am L	1:59 pm H	8:17 pm L
28	TH	2:11 am H	8:57 am L	2:42 pm H	8:59 pm L
29	FR	2:49 am H	9:38 am L	3:24 pm H	9:39 pm L
30	SA	3:28 am H	10:17 am L	4:08 pm H	10:17 pm L

Hudson

1	FR	1:20 am L	6:44 am H	2:12 pm L	7:37 pm H
2	SA	1:55 am L	7:15 am H	2:53 pm L	8:25 pm H
3	SU	2:30 am L	7:39 am H	3:33 pm L	9:12 pm H
4	MO	3:09 am L	8:10 am H	4:14 pm L	10:00 pm H
5	TU	3:58 am L	8:55 am H	4:58 pm L	10:48 pm H
6	WE	5:00 am L	9:48 am H	5:46 pm L	11:37 pm H
7	TH	6:08 am L	11:01 am H	6:36 pm L	
8	FR	12:27 am H	7:16 am L	12:25 pm H	7:29 pm L
9	SA	1:16 am H	8:19 am L	1:29 pm H	8:22 pm L
10	SU	2:02 am H	9:18 am L	2:26 pm H	9:15 pm L
11	MO	2:45 am H	10:14 am L	3:17 pm H	10:07 pm L
12	TU	3:25 am H	11:07 am L	4:06 pm H	10:58 pm L
13	WE	4:06 am H	11:59 am L	4:54 pm H	11:48 pm L
14	TH	4:48 am H	12:49 pm L	5:45 pm H	
15	FR	12:40 am L	5:36 am H	1:39 pm L	6:40 pm H
16	SA	1:32 am L	6:30 am H	2:30 pm L	7:39 pm H
17	SU	2:26 am L	7:33 am H	3:21 pm L	8:39 pm H
18	MO	3:23 am L	8:40 am H	4:14 pm L	9:38 pm H
19	TU	4:21 am L	9:46 am H	5:07 pm L	10:36 pm H
20	WE	5:22 am L	10:49 am H	6:00 pm L	11:34 pm H
21	TH	6:23 am L	11:50 am H	6:53 pm L	
22	FR	12:30 am H	7:23 am L	12:49 pm H	7:46 pm L
23	SA	1:27 am H	8:21 am L	1:45 pm H	8:36 pm L
24	SU	2:15 am H	9:16 am L	2:38 pm H	9:25 pm L
25	MO	3:03 am H	10:08 am L	3:27 pm H	10:11 pm L
26	TU	3:47 am H	1:07 am L	4:14 pm H	10:55 pm L
27	WE	4:29 am H	11:42 am L	4:59 pm H	11:36 pm L
28	TH	5:07 am H	12:25 pm L	5:43 pm H	
29	FR	12:16 am L	5:44 am H	1:05 pm L	6:26 pm H
30	SA	12:53 am L	6:17 am H	1:44 pm L	7:09 pm H

Albany

1	FR	1:20 am L	6:44 am H	2:12 pm L	7:37 pm H
2	SA	1:55 am L	7:15 am H	2:53 pm L	8:25 pm H
3	SU	2:30 am L	7:39 am H	3:33 pm L	9:12 pm H
4	MO	3:09 am L	8:10 am H	4:14 pm L	10:00 pm H
5	TU	3:58 am L	8:55 am H	4:58 pm L	10:48 pm H
6	WE	5:00 am L	9:48 am H	5:46 pm L	11:37 pm H
7	TH	6:08 am L	11:01 am H	6:36 pm L	
8	FR	12:27 am H	7:16 am L	12:25 pm H	7:29 pm L
9	SA	1:16 am H	8:19 am L	1:29 pm H	8:22 pm L
10	SU	2:02 am H	9:18 am L	2:26 pm H	9:15 pm L
11	MO	2:45 am H	10:14 am L	3:17 pm H	10:07 pm L
12	TU	3:25 am H	11:07 am L	4:06 pm H	10:58 pm L
13	WE	4:06 am H	11:59 am L	4:54 pm H	11:48 pm L
14	TH	4:48 am H	12:49 pm L	5:45 pm H	
15	FR	12:40 am L	5:36 am H	1:39 pm L	6:40 pm H
16	SA	1:32 am L	6:30 am H	2:30 pm L	7:39 pm H
17	SU	2:26 am L	7:33 am H	3:21 pm L	8:39 pm H
18	MO	3:23 am L	8:40 am H	4:14 pm L	9:38 pm H
19	TU	4:21 am L	9:46 am H	5:07 pm L	10:36 pm H
20	WE	5:22 am L	10:49 am H	6:00 pm L	11:34 pm H
21	TH	6:23 am L	11:50 am H	6:53 pm L	
22	FR	12:30 am H	7:23 am L	12:49 pm H	7:46 pm L
23	SA	1:24 am H	8:21 am L	1:45 pm H	8:36 pm L
24	SU	2:15 am H	9:16 am L	2:38 pm H	9:25 pm L
25	MO	3:03 am H	10:08 am L	3:27 pm H	10:11 pm L
26	TU	3:47 am H	10:57 am L	4:14 pm H	10:55 pm L
27	WE	4:29 am H	11:42 am L	4:59 pm H	11:36 pm L
28	TH	5:07 am H	12:25 pm L	5:43 pm H	
29	FR	12:16 am L	5:44 am H	1:05 pm L	6:26 pm H
30	SA	12:53 am L	6:17 am H	1:44 pm L	7:09 pm H

Castleton

1	FR	12:51 am L	6:27 am H	1:43 pm L	7:20 pm H
2	SA	1:26 am L	6:58 am H	2:24 pm L	8:08 pm H
3	SU	2:01 am L	7:22 am H	3:04 pm L	8:55 pm H
4	MO	2:40 am L	7:53 am H	3:45 pm L	9:43 pm H
5	TU	3:29 am L	8:38 am H	4:29 pm L	10:31 pm H
6	WE	4:31 am L	9:31 am H	5:17 pm L	11:20 pm H
7	TH	5:39 am L	10:44 am H	6:07 pm L	
8	FR	12:10 am H	6:47 am L	12:08 pm H	7:00 pm L
9	SA	12:59 am H	7:50 am L	1:12 pm H	7:53 pm L
10	SU	1:45 am H	8:49 am L	2:09 pm H	8:46 pm L
11	MO	2:28 am H	9:45 am L	3:00 pm H	9:38 pm L
12	TU	3:08 am H	10:38 am L	3:49 pm H	10:29 pm L
13	WE	3:49 am H	11:30 am L	4:37 pm H	11:19 pm L
14	TH	4:31 am H	12:20 pm L	5:28 pm H	
15	FR	12:11 am L	5:19 am H	1:10 pm L	6:23 pm H
16	SA	1:03 am L	6:13 am H	2:01 pm L	7:22 pm H
17	SU	1:57 am L	7:16 am H	2:52 pm L	8:22 pm H
18	MO	2:54 am L	8:23 am H	3:45 pm L	9:21 pm H
19	TU	3:52 am L	9:29 am H	4:38 pm L	10:19 pm H
20	WE	4:53 am L	10:32 am H	5:31 pm L	11:17 pm H
21	TH	5:54 am L	11:33 am H	6:24 pm L	
22	FR	12:13 am H	6:54 am L	12:32 pm H	7:17 pm L
23	SA	1:07 am H	7:52 am L	1:28 pm H	8:07 pm L
24	SU	1:58 am H	8:47 am L	2:21 pm H	8:56 pm L
25	MO	2:46 am H	9:39 am L	3:10 pm H	9:42 pm L
26	TU	3:30 am H	10:28 am L	3:57 pm H	10:26 pm L
27	WE	4:12 am H	11:13 am L	4:42 pm H	11:07 pm L
28	TH	4:50 am H	1:56 am L	5:26 pm H	11:47 pm L
29	FR	5:27 am H	12:36 pm L	6:09 pm H	
30	SA	12:24 am L	6:00 am H	1:15 pm L	6:52 pm H

Troy

1	FR	1:30 am L	6:52 am H	2:22 pm L	7:45 pm H
2	SA	2:05 am L	7:23 am H	3:03 pm L	8:33 pm H
3	SU	2:40 am L	7:47 am H	3:43 pm L	9:20 pm H
4	MO	3:19 am L	8:18 am H	4:24 pm L	10:08 pm H
5	TU	4:08 am L	9:03 am H	5:08 pm L	10:56 pm H
6	WE	5:10 am L	9:56 am H	5:56 pm L	11:45 pm H
7	TH	6:18 am L	11:09 am H	6:46 pm L	
8	FR	12:35 am H	7:26 am L	12:33 pm H	7:39 pm L
9	SA	1:24 am H	8:29 am L	1:37 pm H	8:32 pm L
10	SU	2:10 am H	9:28 am L	2:34 pm H	9:25 pm L
11	MO	2:53 am H	10:24 am L	3:25 pm H	10:17 pm L
12	TU	3:33 am H	11:17 am L	4:14 pm H	11:08 pm L
13	WE	4:14 am H	12:09 pm L	5:02 pm H	11:58 pm L
14	TH	4:56 am H	12:59 am L	5:53 pm H	
15	FR	12:50 am L	5:44 am H	1:49 pm L	6:48 pm H
16	SA	1:42 am L	6:38 am H	2:40 pm L	7:47 pm H
17	SU	2:36 am L	7:41 am H	3:31 pm L	8:47 pm H
18	MO	3:33 am L	8:48 am H	4:24 pm L	9:46 pm H
19	TU	4:31 am L	9:54 am H	5:17 pm L	10:44 pm H
20	WE	5:32 am L	10:57 am H	6:10 pm L	11:42 pm H
21	TH	6:33 am L	11:58 am H	7:03 pm L	
22	FR	12:38 am H	7:33 am L	12:57 pm H	7:56 pm L
23	SA	1:32 am H	8:31 am L	1:53 pm H	8:46 pm L
24	SU	2:23 am H	9:26 am L	2:46 pm H	9:35 pm L
25	MO	3:11 am H	10:18 am L	3:35 pm H	10:21 pm L
26	TU	3:55 am H	11:07 am L	4:22 pm H	11:05 pm L
27	WE	4:37 am H	11:52 am L	5:07 pm H	11:46 pm L
28	TH	5:15 am H	12:35 pm L	5:51 pm H	
29	FR	12:26 am L	5:52 am H	1:15 pm L	6:34 pm H
30	SA	1:03 am L	6:25 am H	1:54 pm L	7:17 pm H

TIDES June

TIDES June

Your local on-water assistance experts.

JOIN NOW!

\$179
a year
49¢
a day!

SEA TOW

800-4-SEATOW

seatow.com

CORTLANDT YACHT CLUB

WELCOME TO ONE OF THE HUDSON RIVER'S PREMIER YACHT CLUBS.



WE ARE LOCATED IN MONTROSE NY.

5.5 MILES SOUTH OF THE BEAR MOUNTAIN BRIDGE. 12.5 MILES NORTH OF THE TAPPAN ZEE.

Our members enjoy the shelter of a sturdy break-wall in the protection of Greens Cove. In addition, CYC is a rare commodity tucked-away and isolated from highways and train tracks. Whether you're casting off or dining-in, you will enjoy the amenities of CYC. We offer summer slips for vessels ranging from PWC to 50 foot and land storage as well.

SERVICES INCLUDE:

**PUMP OUT | ELECTRIC (30 AND 50 AMP) | HAULING | WINTER STORAGE | OUTDOOR CAFÉ
OLYMPIC POOL & DIVING POOL | CHILDREN'S PLAYGROUND | CLUB HOUSE | MANY CLUB FUNCTIONS**

MEMBERSHIPS AVAILABLE - CALL JESSE BRODY AT 914-882-8810 FOR MORE INFO

BIG SAVINGS BEING A MEMBER

**CALL JOHN MOURGES FOR
SLIP RENTALS: 845.590.7507**



**SUMMER SLIPS INCLUDE POOL
MEMBERSHIPS FOR LESS THEN
OTHER MARINA'S:**



**CONTACT US NOW!
FILLING UP FAST.**

**CALL RON FEDELE FOR
CLUBHOUSE RENTALS:
914.841.0544**



**ROB'S CAFÉ OPENING MEMORIAL DAY
WEEKEND ON FRIDAY.
POOL MEMBERSHIPS & TRANSIENT SLIPS**



CONTACT KAREN AT: 914.433.5281



30 TON TRAVEL LIFT

**A FEW EXCELLENT
SLIPS AVAILABLE.
CALL FOR SIZES!**

**CORTLANDT YACHT CLUB • 238 KINGS FERRY RD • BOX 119 • MONTROSE, NY 10548
OFFICE : 914.739.3011 • EMAIL : YACHT@OPTONLINE.NET • WEB : CORTLANDTYACHTCLUB.COM**



Celebrate
2018 with us
this summer!

For a list of events:
canals.ny.gov

Corning GlassBarge is coming to an event near you!



Dedicated individuals who

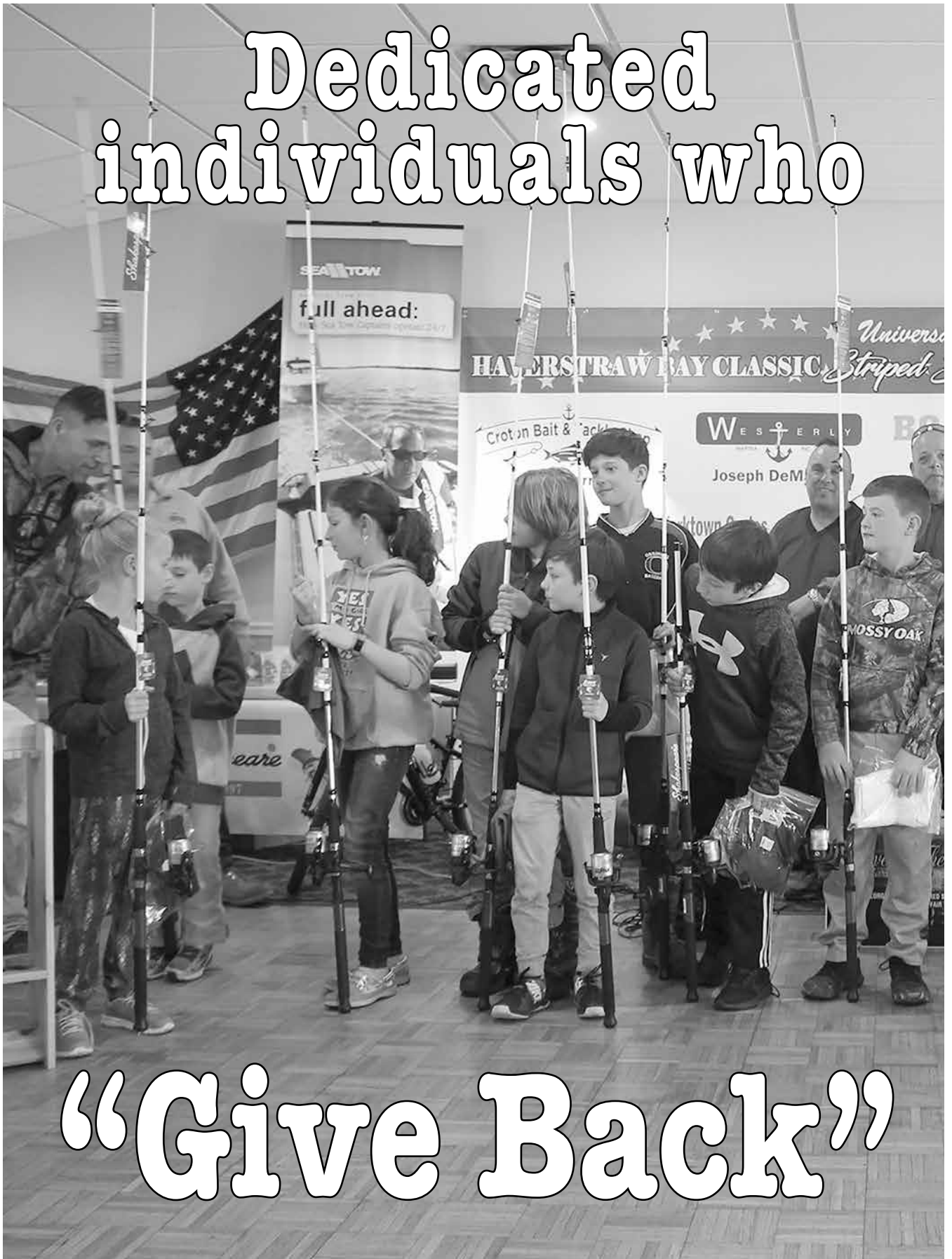

“Give Back”

by **John H. Vargo,**
Publisher

al Handyman Presents the 2018
Bass Tournament Hosted by
CORTLANDT YACHT CLUB



As I have gotten older, and continue to roam the “river” which I love to do, I realize, more and more the tremendous number of individuals who donate their time, money and energy to supporting the things they love dearly.

In many of these folks lays a latent desire to have others enjoy what they have been enjoying in and around the Hudson River all their lives.

Among the folks that “get it” are the ones that try to influence children. None work harder at that than Pat Harbolic, and Tom Colandro, who, with a number of other

volunteers, created the Haverstraw Bay Classic, a striped bass derby with emphasis on teaching children about the tremendous population of healthy, vibrant, fish their are in the Hudson River!

April 27, 28, 29, and 2018 all this came together with over \$12,000 in prizes, 230 entries, over 30 volunteers and the complete cooperation of the Cortlandt Yacht Club who donated their beautiful clubhouse to the event.



The winner of the top prize in the youth division was Nick Bartelemeo who not only won the kayak but a load of supplies to go with it! He is the perfect age to use this fishing kayak anywhere he feels it is safe enough to do so. Matts Sporting Goods of Haverstraw, NY, donated the prize.

With over 130 people at the windup dinner the volunteers in the kitchen and at the grill had their hands full.

I can tell you folks that were not there this was the smoothest most professional windup of a fishing event that I have witness in doing over 100 of these events.

If it gets better than this in 2019 you will be sorry you missed the upcoming event.

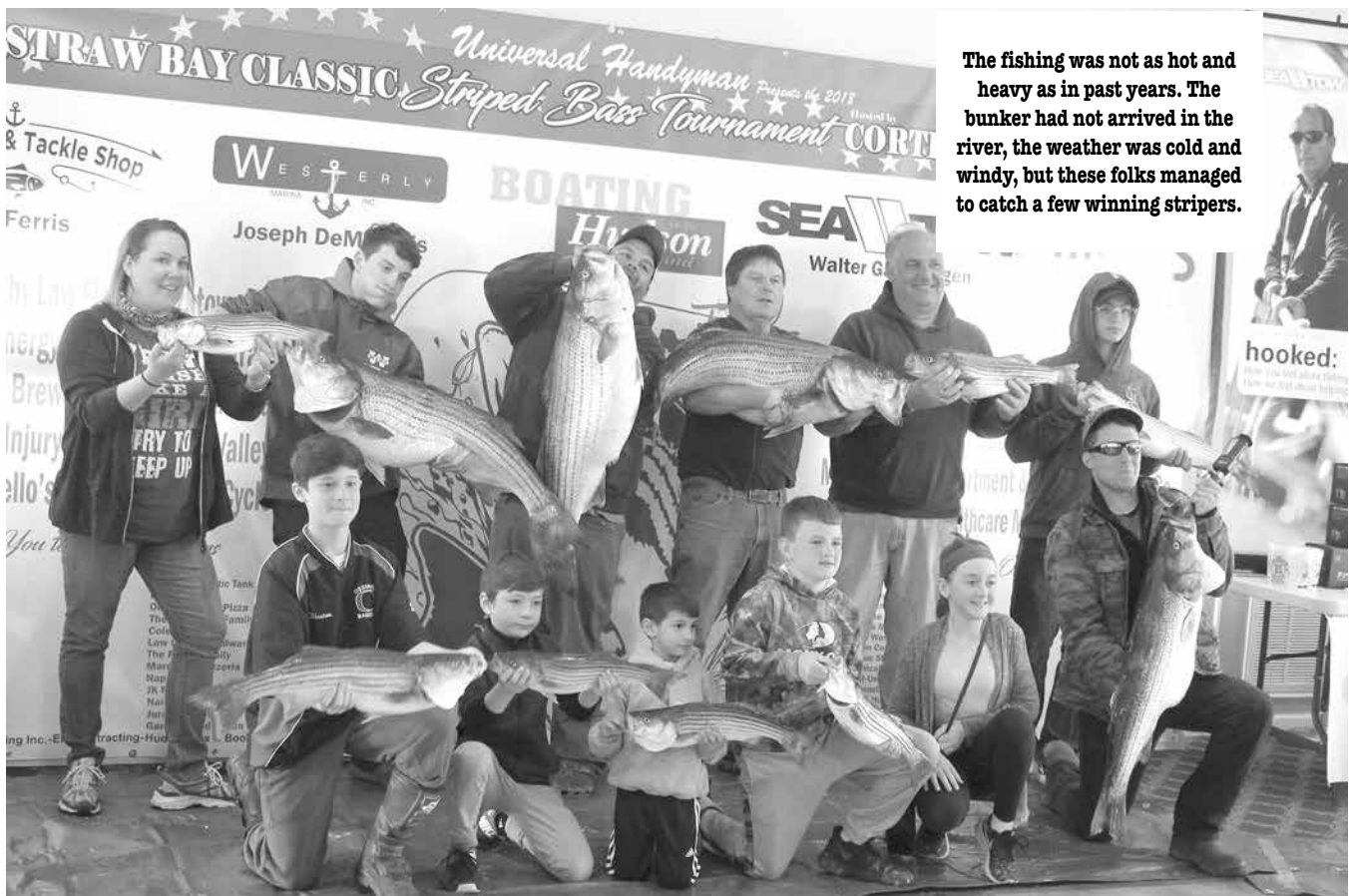

The fishing was not as hot and heavy as in past years. The bunker had not arrived in the river, the weather was cold and windy, but these folks managed to catch a few winning stripers.



These two men Butchey Gilmore and Joe Disclafani produced enough hot dogs, hamburgers and delicious fresh caught striped bass to satisfy the huge crowd that attended the windup awards ceremony!



Addison Temple, girl 13 and under champion



Mike Barksdale, 5th place in adult division

HAGER'S HARBOR FOR SALE

1,740,000

10 BRICK ROW RD ATHENS, NY 12015



PREPOSED
RV PARK

Hudson River



TURN-KEY
RESTAURANT ON
THE RIVER

Hudson River

PHONE » 518-965-3018 | WEB » WINMORRISONREALTY.COM



**TAPPAN ZEE
MARINA**

*Under New
Management!*

- Full-Service Marina and Boatyard
- Pier 701 Restaurant and Bar
- Ship Store with Ice and Beverages
- Walking Distance to Downtown Piermont
- Professionally Managed by Oasis Marinas

Piermont, NY
www.tappanzeemarina.com
845-359-5522





PREMIERE YACHTING DESTINATION

THE ONLY CALM WATER MARINA IN NEW YORK HARBOR,
LOCATED IN SCENIC LIBERTY STATE PARK

Our marina store offers marine supplies, food, clothing,
beer, wine and the best of marine electronics.



 **PETTIT PAINT**

YANMAR

Onan

 **MERCURY**

KOHLER

VOLVO

Liberty State Park
80 Audrey Zapp Drive
Jersey City, NJ

LibertyLandingMarina.com
201-985-8000

Reserve Your
Transient Slip **NOW** At

Reservations@LibertyLandingMarina.com

Latitude:
40° 42.63' N
Longitude:
74° 2.494' W
VHF: 72

by **John H. Vargo**, *Publisher*



May 12th, 2018 had to be one of the worst days to hold a fishing contest yet, because of the tremendous warmth and “heart” of everyone concerned, turned in to the most successful Hudson River Fisherman Association gathering we ever had. Over 60 people showed up, braved the pouring rain, smiling, happy and ready to catch fish. And catch fish they did, over 35 catfish, stripers, perch, carp were caught, weighed and released back into the Hudson River. This in a matter of 3 hours of dismal, to say the least, bad weather.

It is the goal of the HRFA to introduce children in particular, as well as their parents, to the joys of fishing and this certainly was accomplished on this Saturday.

Thanks to the Wounded Warrior Project every child who attended received a high quality rod. First, Second, and Third place winners received many more fishing items. Congratulations to all, especially the Wounded Warriors who attended despite the weather!

Gil Hawkins, HRFA, (In his home made rain coat) and Simone, wife of one of the Wounded Warriors who attended. While this lady had never fished before she picked up on it quickly and did manage to catch a few fish.



PURE JOY!

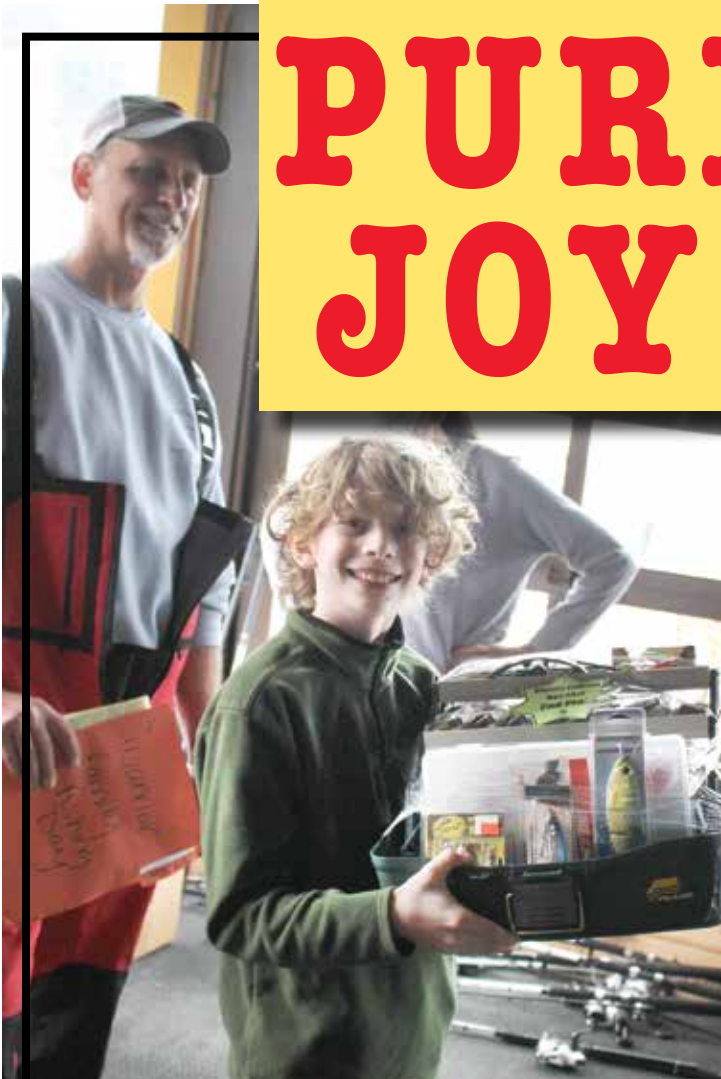

The huge smile, and arm load of fishing equipment won while fishing, at the 3rd annual Wounded Warrior Catfish Derby, says it all! Luncheon held at the hospitable Billy Joe's Rib Works deck in Newburgh, NY.



Mrs. Nancy Schiliro, Alumni Specialist for the Wounded Warrior Project, doing a chant for the rain to stop while Schot Havner in charge of the event for the HRFA encourages her.



The luncheon of over 60 wounded warriors from all walks of life enjoyed the hospitality of lunch after a few hours on the cold, wet deck of Billy Joe's Rib Works. A resounding success to a very eventful day for everyone.



VIKING BOATYARD



SUMMERTIME!

Everything You Need To Get In The Water!

LOCATED 10 MILES
NORTH OF THE TAPPEN
ZEE BRIDGE ON
THE HUDSON RIVER

914-739-5090 914-739-5171 fax
50 - 6TH STREET, VERPLANCK, NY 10596
email: INFO@VIKINGBOATYARD.COM

- SHIP STORE
- DO-IT-YOURSELF
- RESTAURANT
- JET SKI DOCKS

RIVERVIEW MARINE SERVICES INC.

103 Main Street Catskill NY 12414



EVINRUDE® E-TEC® G2™ 300 HP

150 HP 175 HP 200 H.O. 225 HP
225 H.O. 250 HP 250 H.O. 300 HP

BRP
PLATINUM
CERTIFIED



THE ALL-NEW EVINRUDE E-TEC G2 The outboard of the future.

Monday - Saturday 8 AM to 5:00 PM and Sunday 9 AM to 5:00 PM or by appointment

OFFICE • 518.943.5311 | EMAIL • RVRVWMIKE@AOL.COM | WEB • RIVERVIEWMARINESERVICES.COM

COEYMAN'S LANDING MARINA

BREAK WALL RUNS THE
ENTIRE LENGTH OF MARINA.
AT HIGH TIDE IT IS COVERED.
SOUTH ENTRANCE AT
CHANNEL MARKER 189. CALL
ON YOUR VHF RADIO OR CALL
THE SHIP STORE WITH
ANY QUESTIONS.

**NEWLY REMODELED
SHIP STORE
UNDER NEW MANAGEMENT**

- NEW BOATS •
- PRE-OWNED BOATS •
- DEALER DEMOS •
- BIG BOATS •
- SMALLER BOATS •
- BROKERAGE BOATS •
- JET SKI PORT •

**WE ARE LICENSED
BROKERS OF NEW
& USED BOATS**

**THE PREMIER BOAT
BROKERAGE MARINA
IN THE NORTHEAST!**

*IF WE DON'T HAVE IT WE
CAN FIND IT FOR YOU*

**WHY DO WE SELL SO
MANY BOATS?**

SELLING BOATS IS NOT
A SIDELINE FOR US, IT'S
WHAT WE DO.

STRIPER SEASON 2018

\$200.00 FOR THE STRIPER
SEASON. NO WATER OR
ELECTRIC.

**NEW LOWER PRICES FOR JETSKI'S!
IT IS \$400.00 FOR THE SEASON.**

**NORTH DOCK, LOWER PRICES... \$35.00 PER FT.
NO WATER OR ELECTRIC. UP TO 22'**

A FULL SERVICE MARINA

- MAGNET** GAS & DIESEL • • FREE WI-FI + CABLE TV
- 38 TON TRAVEL LIFT / LOCK PERMITS • • CLEAN SHOWERS AND REST ROOMS
- ICE-LAUNDRY / LP • • **FACTORY TRAINED** MERCURY MARINE
- BAIT & TACKLE • • CERTIFIED MECHANICS

518-756-6111 | COEYMANSLANDING.COM
8 MILES SOUTH OF ALBANY ON THE HUDSON RIVER

RONDOUT YACHT BASIN
ON THE HUDSON RIVER

Enjoy Summer With Us!

TOUR
AN HISTORIC LIGHTHOUSE

EXPLORE
KINGSTONS WATERFRONT

SWIM
IN OUR COOL POOL

RYB IS THE #1 DESTINATION FOR BOAT CLUB RENDEZVOUS !!! COME JOIN THE FUN

BOATERS' CHOICE 2017
marinas.com

SWIMMING POOL | OUTDOOR CAFE ON OUR DOCK | BARBECUE & PICNIC AREAS | GENERAL STORE
BOATING SUPPLIES GAS & DIESEL | WIFI | MAST STEPPING & RIGGING
45 TON TRAVEL LIFT | SHOWERS & LAUNDRY | 91 OCTANE ETHANOL FREE GAS

ON PREMISES
WATERCOLORS FIBERGLASS REPAIR SHOP | MECHANICAL REPAIR & SERVICE
HUDSON VALLEY CUSTOM CANVAS *with Bonnie Coliukos*

102 First Street • Connelly, NY 12417
(845) 331-7061 | RondoutYachtBasin.com

8th Annual Bank of Greene County
"Leo Lasher"

\$15.00 ENTRY FEE

United Way of Columbia and Greene Counties
CATFISH DERBY Team Challenges Prizes for ALL Ages
Dutchman's Landing • Catskill, NY

*** 2:00PM CUT-OFF ***
\$1500.00 CASH PRIZE LONGEST LIVE CHANNEL CATFISH

PRE-REGISTRATION REQUIRED

At any branch of The Bank of Greene County or
www.unitedwaycatfishderby.com * DEADLINE 11:00PM JULY 20, 2018

SET THE NYS RECORD CATFISH !!!!!
WIN A Village Dodge **TRUCK**
and a **BOAT, MOTOR, and TRAILER**
FROM RIVERVIEW MARINE

SEQUENCE DEVELOPMENT

JULY 21, 2018
United Way

SEE OUR FACEBOOK PAGE: <https://www.facebook.com/unitedwaycatfishderby/>
CONTACT BRAD POSTER AT 518.755.2155



Eels: The Creatures from the Sargasso Sea!

A 3,000 mile trip
to reach Albany.

by **Garrett McCarey**

The eel is not a very likable creature at first glance. It is secretive, snake-like, slimy, and, as those who have inadvertently caught one while angling know, very, very strong. It is the last thing you want to see on your fishing line! My take on eels has always been one of wonderment as one of my earliest childhood memories is of watching young eels (elvers) climbing straight up a small dam on a tiny creek across the street from where I lived. What were these things? As a boy I caught the adult eel in the Oscawana brook behind our house in Putnam Valley. Fishing for them was particularly good when “they let the pool go” which meant that upstream Floradan Lodge opened the gateway of their brook-dammed swimming pool to clear the silt. The now dark brown and swirling waters of our usually pristine brook brought out the eels which we caught with a ball of dough from squeezed Wonderbread or a nice fat night crawler. We skinned them and roasted them over an open fire, as we did with any fish we caught, unaware of their arduous journey or unlikely life history.

Which brings us back as to why we were standing in the tidal entrance of the ice cold Poestenkill in Troy, NY just a few miles south of Lock One, the terminus of the estuarine Hudson River.

A local fisherman who was scouting the kill for any sign of herrings saw the fyke net and asked
“you catching bait?”

It was a cold late April day as my trusted companions, Molly, Samantha and Lilly, ages nine through twelve, and I waded through the 39 degree water of the Poestenkill to our fyke net. With help from Jeff Briggs, a volunteer from the Rensselaer Plateau Association, we emptied its cod end into the bucket. Nothing! Was it the late Spring or the recent rains? The herring were not running yet so perhaps in a few days...

And what was our intended quarry? Eels, baby eels, little creatures with glassine bodies only two or three inches long. Eels that are in the home stretch of a miraculous journey of some 1500 miles!

"Nope. Eels"

"Whatcha doin' that for?"

"To count 'em"

He gave us a puzzled look and headed home. His interest was in the run of herrings which he would use as bait for Striped Bass. The bass follow the herring upriver.

Yes, we were there to count eels.

The American Eel (*Anguilla rostrata*) is a diadromous fish, capable of living in both freshwater and seawater as are striped bass, shad and other herring

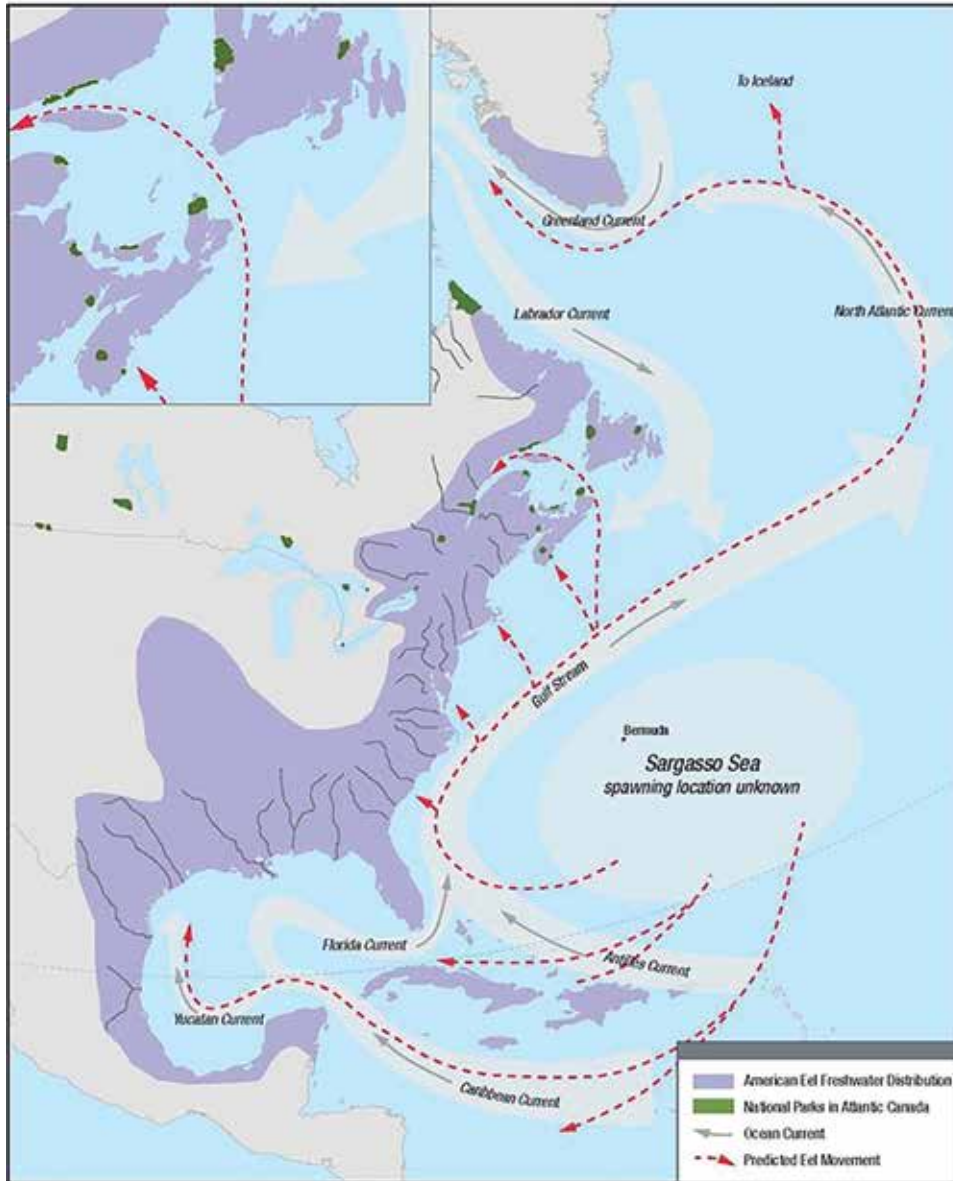

species. It's the alewife that the fisherman was looking for as baitfish. The difference between these fish and the eel is that they are anadromous, living their adult lives in saltwater and returning to freshwater only to spawn, though some say there is a resident population of stripers in the river. The eel, on the other hand, lives its adult life in freshwater and returns to the sea to spawn. The adult eels are called brown or yellow eels and when sexually mature, the age is unclear but it could be eight to fifteen years, they become

silver eels with bulging eyes, darkened backs and a silver sheen to their bellies and they head downstream.

James Prosek in his book "Eels...the world's most mysterious fish" describes a working eelman in the Delaware River where, under a new moon and after a good rain in September, thousands of silver eels begin their migration back to the sea and his year long work on his stone weir finally pays off on these two nights. And where are the eels headed? The Sargasso Sea. This is an area in the Atlantic Ocean between the Gulf Stream that includes the Bermuda Triangle. Known as the graveyard of lost ships this becalmed sea is covered with a mass

of algae, plastic and other flotsam. It is here, at depths of 1,300 to 2,300 feet that the eels, both the American and the European varieties, spawn. No one knows exactly where this happens or what triggers it. This has got to be some wild eel party!

The eel eggs hatch into little leaf-like transparent water creatures called leptocephali and after a year of drifting over the continental shelf they metamorphose into glass eels which then swim up the rivers and tributaries. This was what we were after!

We were working as citizen scientists through the New York State Department of Environmental Conservation (DEC) and I was a volunteer working for NATURE Lab, a project of the Sanctuary for Independent Media in Troy, NY. I had heard of the Eel Project and thought it would be a great way for the community to learn about the Hudson River. There is no better classroom than the great outdoors where learning to become wet and dirty is an essential part of the syllabus. I contacted their Citizen Science group in the Hudson River Estuary Program and, much to my surprise, they thought that a week long trial run in the Poestenkill was a good idea as their most northern sampling station was in Ravena on the Hannacroix Creek about a half hour South of Albany. (They did a trial run in the Wynantskill near Troy in 2017 with no success.) The Eel Project began in 2008 with two sites and now has 14 sites sampling the Hudson River's tributaries by over 750 volunteers and students. Our team included students from Dan Capuano's Ecology class at Hudson Valley Community College, and students from RPI, Russell Sage and

Skidmore and the three girls from Brittonkill Elementary School that I enlisted by promising them a life changing experience.

After five days of sampling we caught two pigmented elvers about five inches long but no glass eels. It was still great fun, putting on waders or hip boots (Molly's leaked) and pulling up the net but we really needed to see this near mythical life form that we were pursuing. So I headed down to Hannacroix Creek where, at low tide, a half a dozen volunteers from the New Baltimore Conservancy converged.

COEYMANS LANDING MARINE SERVICES, INC.

MERCUISER • MERCURY OUTBOARDS • O.M.C. MEGA PARTS INVENTORY

OUR TEAM DOES IN ALL!

SPECIALIZING IN ELECTRONICS

CONSULT WITH
JIMMY OR
CARL BEFORE
YOU INVEST IN
NEW ELECTRONICS



LOCALLY OWNED & OPERATED
BY JIM COSTELLO & CARL SENTER

(518) 756-7400 | P.O. BOX 664 • 20 MARINA DRIVE COEYRNANS, NY 12045

Among them was a visitor from England who wanted to replicate the Eel project in her home country as the European Eel's numbers have been decimated to ten per cent of its population. Unlike in America, eels are prized as culinary delicacies in Europe and East Asia and with the Asian eel population also severely compromised there is a huge and very profitable market for glass eels from Europe. Eelers can "rake in" \$1500 to \$2500 (£1100 to £1800) per pound. These eels are shipped to Asia and raised in aquaculture ponds as there is no known way of producing eel eggs in a laboratory. In the U.S. there are only two states, North Carolina and Maine, that allow elver and glass eel fishing. On Cape Cod authorities are on high alert for eel poachers coming down from Boston to earn a few grand in this illegal and lucrative market. This why the eel population in the tributaries need to be monitored.

The Hannacroix crew was ready for another catch as numerous as they had had the day before. I was ready to see the elusive glass eel and, Holy Poseidon!, did I see them. It took the team two and a half hours to count 3,557 eels, a mass of slithering wormlike beasts. The eels were quite the hit and we showed them to anyone who might be remotely interested. And they were. These eels were deemed "cute", "amazing", "unbelievable." This was a far cry from the word association one would normally get from the word "eel." A small success. These are animals you would never see in your lifetime even in the largest and most well stocked aquariums of the world. And they are right here in our backyard.

On Friday our trial week was up and we were going to remove the net. Gracie and Aidan from DEC came up to do the deed. I felt we had failed, but wait! There were herring in the kill and the temperature had risen to 48 degrees. There was

more! Gracie pointed out that the fyke net was coated with herring eggs and, look around, the low tide exposed rocks and the creek bottom covered with them, millions of eggs in a layer an inch thick! I had never seen such a sight in my life. But the best thing of all – we caught a glass eel! One glass eel. We were ecstatic. We considered keeping the net in for another week but the students were in the midst of studying for finals and if we caught as many eels as they had downriver we would be severely short handed.

We took the little guy or gal up the kill past the Poestenkill Gorge and set it free above the dam near the cemetery. After such a long journey of so many thousands of miles we gave this traveler a bit of a break, it wouldn't have to climb the falls. It was home free.

The great news is that Aidan thought we should continue to sample next year, perhaps for the full extent of the run. That one little eel did the trick, I think. If we do sample we'll need all the help we can get. If you're interested in sampling in 2019 please get in touch with the NATURE Lab, believe me, you will not regret it and the "Creatures from the Sargasso Sea" will be better for it.

For information and data on the Eel Project go to WWW.DEC.NY.GOV and search for "eel project".

To become a volunteer eel counter on the Poestenkill go to MEDIASANCTUARY.ORG and click on NATURE Lab.

For further reading:

"Eels, an exploration, from New Zealand to the Sargasso, of the World's Most Mysterious Fish" by James Prosek; Harper/Collins

"Consider the Eel" by Richard Schweid; University of North Carolina Press.

MINISCEONGO YACHT CLUB



EVERYTHING OUR MEMBERS AND THEIR FAMILY NEEDS FOR THEIR PERSONAL TIME.

- » 140 Slips on six docks in a fully protected basin
- » Park like grounds with grills & picnic areas at each dock
- » New clubhouse construction
- » Large pavillion for social activities
- » Two week Junior Sail Camp
- » Bathrooms, showers and laundry
- » Large boat storage yard
- » 35 ton travel lift - boats up to 48 feet
- » Launch ramp
- » Associate Members can work toward regular membership



WELCOME TRANSIENTS

RECIPROCAL TRANSIENT SLIPS AVAILABLE AND WELCOME WITH OTHER YACHT CLUBS

MINISCEONGOYC.ORG | INFO@MINISCEONGOYC.ORG
PO BOX 572, 83 GRASSY POINT RD | STONY POINT, NY 10980

\$1,325,000

FANTASTIC OPPORTUNITY - CAN BE OPENED AS A RESTAURANT OR BRING YOUR DREAMS TO REALITY!

OFFICE ADDRESS:
2000 NY-303,
ATHENS, NY 12015

WWW.LAKEANDMOUNTAINLLC.COM

LISTING BROKER » PATRICIA MEYERS | LISTING AGENT » KELLI FORSCHNER: 518-731-3222

SCARANO BOAT BUILDING

We work on all types of vessels:
WOOD | COMPOSITE | STEEL | ALUMINUM

We have the capacity to rebuild Structurally, Cosmetically, and to Design and Install systems. We also Repower and Install gensets.

518.860.1969 | 194 SOUTH PORT RD • ALBANY, NY 12202-1075 | ERIC.E@SCARANOBOAT.COM

SCARANOBOAT.COM

THE VIETNAM TRAVELING MEMORIAL WALL ®

THE WALL THAT HEALS

THE WALL THAT HEALS, A 375- FOOT REPLICA OF THE
VIETNAM VETERANS MEMORIAL
ALONG WITH A MOBILE EDUCATION CENTER, IS SCHEDULED TO VISIT THE
CITY OF NEWBURGH | AUGUST 2ND TO AUGUST 5TH
ON THE NEWBURGH WATERFRONT



The Wall That Heals honors the more than three million Americans who served in the U.S Armed forces during the Vietnam War and it bears the name of the more than 58,000 men and women who made the ultimate sacrifice.

When The Wall was dedicated in 1982, visitors began making rubbings of the names on The Wall. This began the tradition of visitors taking home a name rubbing as a keepsake of their visit. Paper and pencils will be provided.

The 53-foot trailer that carries The Wall That Heals transforms to become a mobile Education Center. The exterior of the trailer features a timeline of "The War and The Wall" and provides additional information about the Vietnam Veterans Memorial in Washington, D.C. Additional exhibits give visitors a better understanding of the legacy of the Vietnam Veterans Memorial and the collection of items left at The Wall.



PLEASE DRINK RESPONSIBLY 2056906

FUELING the BOAT

Please note: We strongly suggest you call ahead to your fueling location!

Well, your boat is in the water, about to go in the water, it's your first time on the Hudson River, or you are a first time boat owner and need to know where to get fuel. Below we have provided a complete and comprehensive list of all of the fuel docks on the Hudson River (to the best of our knowledge). We strongly suggest that you call ahead to be sure that they are open when you get there.

Fuel Docks:

South of the George Washington Bridge

- Liberty Landing Marina, Western Shore, Jersey City, NJ
- Liberty Harbor Marina, Western Shore, Jersey City, NJ
- Lincoln Harbor Yacht Club, Western Shore, Weehawken, NJ

North of the George Washington Bridge

- JM Englewood Marina, Western Shore, Englewood, NJ
- Alpine Boat Basin, Western Shore, Alpine, NJ
- Tappan Zee Marina, West Shore, Piedmont, NY, operated by Oasis Marine Services

North of the Tappan Zee Bridge

- Tarrytown Marina, Eastern Shore, Tarrytown, NY
- Westerly Marina, Eastern Shore, Ossining, NY
- Haverstraw Marina, Western Shore, Haverstraw, NY

North of the Bear Mountain Bridge

- Newburgh Yacht Club, Western Shore, Newburgh, NY

North of the Newburgh/Beacon Bridge

- Whites Hudson River Marina, Eastern Shore, New Hamburg, NY
- West Shore Marine, Western Shore, Marlboro, NY

North of the Poughkeepsie Bridge

- Hyde Park Marina, Eastern Shore, Hyde Park, NY
- Roger's Point Boating Association, Eastern Shore, Hyde Park, NY
- Rondout Yacht Basin, (South Shore of Rondout Creek), Connelly, NY
- Certified Marine Service, (South Shore of Rondout Creek), Connelly, NY
- Lou's Boat Basin (North Shore of Rondout Creek), Kingston, NY

North of Kingston/Rhinecliff Bridge

- Saugerties Marina (South Shore of Esopus Creek), Saugerties, NY
- Riverview Marine Services, (North Shore of Catskill Creek), Catskill, NY
- Hop-O-Nose Marine, Inc. (South Shore of Catskill Creek), Catskill, NY
- Catskill Yacht Club, (South Shore of Catskill Creek), Catskill, NY

North of the Catskill/Hudson Bridge

- Hudson Powerboat Association, Eastern Shore, Hudson, NY
- Coxsackie Yacht Club, Western Shore, Coxsackie, NY
- Donovans's Shady Harbor Marina , (New Baltimore, NY
- Coeymans Landing Marina, Western Shore, Coeymans, NY
- Castleton Boat Club, Eastern Shore, Castleton, NY
- Albany Yacht Club, Eastern Shore, Rensselaer, NY

North of Dunn Memorial Bridge

- Troy Dock, Eastern Shore, Troy, NY
- Troy Motorboat & Canoe Club, Eastern Shore, North Troy, NY
- Schuyler Yacht Basin, Western Shore (Lock 5), Schuylerville, NY
- Whitehall Marina at Lock 12, Western Shore, Whitehall, NY
- Chipman Point Marina, Eastern Shore, Orwell, VT
- Buoy 39 Marina, Eastern Shore, Orwell, VT

- Essex Marina, (On Lake Champlain,) Essex, NY

Detailed listing for each Fuel dock:

LIBERTY LANDING MARINA

(Jersey City, NJ)

LOCATION: Western Shore, 40°

42' 30" -74° 2' 25". Located off the South Side of the Morris Canal. (There is a big Colgate Clock on starboard as you enter the Morris Canal).

INFO: Full Service, Calm Water Refueling Location, 15' Mean low water. Certified Mechanic On Duty, Pump Out, Ice. Visa, Master Card, Discover and American Express.

FUEL: Unleaded Gasoline (89 Octane) and Diesel

HOURS: 24 Hour Credit Card Activated Pump

PHONE: 201-985-8000

VHF Channel 72

WEBSITE: www.libertylandingmarina.com

LIBERTY HARBOR MARINA

(Jersey City, NJ)

LOCATION: Western Shore, 40°

42' 51" -74° 2' 28". Located on the North side of the Morris Canal. INFO: Minimum water on approach is 20' with 20' at the dock. Visa, MasterCard, American Express and Discover are accepted.

FUEL: Unleaded gasoline (89 Octane) and Diesel

HOURS: Open 9AM to 4PM all year (Closed Saturday and Sunday from the end of November to mid-April). Expanded hours for the summer season (May 15th to October 15th) is daily from 8AM to 8PM.

PHONE: 201-516-7500.

WEBSITE: www.libertyharbormarina.com



LINCOLN HARBOR YACHT CLUB

(Weehawken, NJ) LOCATION: Shore, 40° 45' 37" -74° 1' 6".

INFO: Best Fuel Prices In NY Harbor! Slips From 25' To 220', 24 Hour Security Patrol (During The Season), Closed Circuit TV Security System, Electronic Keyed Gates, Yacht Detailing, Dock Hands, Conference Room & Business Services, Laundry & Valet Service, Mechanics On Site, Yacht Sales & Charters, Wi-Fi And Ship Store.

FUEL: Diesel ONLY

HOURS: April 1st thru November 1st, 7am to 5pm Daily.

PHONE: 201-319-5100

WEBSITE: www.lincolnharbormarina.com

JM ENGLEWOOD MARINA

(Englewood Cliffs, NJ)

LOCATION: Western Shore, 40°52'46", -73°56'48" - The marina is located 1.6 miles north of the George Washington Bridge.

INFO: Minimum water on approach is 4' with 5' at the dock. Pump Out, Ice, Bait. Visa MasterCard and Discover accepted.

FUEL: Valvtech Unleaded gasoline (89 Octane) and Diesel

HOURS: Open May 1st thru October 15th, 10AM to 5 PM - 7 Days a week. PHONE: 201-568-1328

WEBSITE: www.jmenglewoodmarina.com

ALPINE BOAT BASIN

(Alpine, NJ) LOCATION: Western Shore, 40° 56' 43" -73° 55' 0". The marina is located south of the repositioned green buoy #5.

INFO: Minimum water on approach is 4' with 4' at the dock. Pump Out (\$5.00/use), Ice, Candy & Soda Machines, Engine Oil, 2 cycle Oil, Star-Tron, Transient Dockage (\$1.00/ft) Visa and Master Card, American Express accepted.

FUEL: Unleaded gasoline (89 Octane)

HOURS: Open May 1st thru November 1st, 9AM to 4:30PM Monday thru Thursday, 9AM to 5:30PM Friday thru Sunday.

PHONE: 201-784-2264

Stewart's Shops Lake George
We are closer to you

Over 265 locations!

Saratoga Springs Albany

with **PREMIUM NON-ETHANOL GAS**

Fill Up Your Boat — AND — Your Cooler...

...in One Easy Stop!

Long Island
stewartsshops.com

& Feeding the Crew

Liberty Landing Marina

(Western Shore in Jersey City, NJ)

201-985-8000, www.LibertyLandingMarina.com

Situated on the Morris Canal in Jersey City at the Statue of Liberty, Liberty Landing Marina's headquarters are located on a large Historical steel lightship. The light- ship has been restored to immaculate condition. What's interesting about this marina and the Liberty State Park adjacent to it is the casual, almost country atmosphere while having the most Spectacular views of the Manhattan Skyline anywhere in New York Harbor. The upper deck of the lightship is used for catered affairs. A water taxi service is available alongside the Lightship to New York City and Jersey City. Individuals and groups find the protected waters of the Morris Canal a desirable location for any kind of rendezvous. There is nothing quite like this anywhere in New York Harbor. Transient docking available \$4 per square foot + electric. If dining at the Liberty House or MaritimeParc free docking offered 2 hours max.

The Liberty House Restaurant and Catering Facility

(Western Shore in Jersey City, NJ)

201-395-0300, www.LibertyHouseRestaurant.com

Located only a few steps away from the docks. Free docking (up to 2 hours) at the marina for restaurant goers. Surrounded by water on three sides, only Liberty House can provide unsurpassable, picture perfect views of the Manhattan skyline, Ellis Island, the Statue of Liberty, and the beautiful Liberty Landing Marina. Hence, our "view with a room." "This is a restaurant to savor as much as to celebrate. Its romantic décor is a seductive lure, as is the food. You'll find comfort food that finds new inspiration in unexpected sources" and boasts both a 10-foot raw bar and a sushi station. Liberty House Restaurant offers both indoor and outdoor terrace seating. Tuesday thru Thursday, dinner hours are 5-10 PM. Friday and Saturday 5-11 PM. Lunch hours are Noon to 3 PM. Sunday brunch hours from 11 to 2 PM. Sunday dinner is from 3 to 8 PM. Closed on Mondays. The Liberty House Restaurant features American contemporary cuisine.

MaritimeParc Restaurant

(Western Shore in Jersey City, NJ) 201-413-0060, www.MaritimeParc.com

Located dockside at Liberty landing Marina, a sleek, modern answer to the coastal fish house, fine dining, raw bar and a friendly accessible vibe. Open Weds -Fri for happy hour and dinner. Lunch and brunch Sat & Sun. Free docking (up to 2 hours) at the marina for restaurant goers.

Liberty Landing NYC

(Eastern Shore in Manhattan, NY)

855-266-3185,

Located at Hudson River Park Pier 25 in lower Manhattan, this dock and mooring field is open for Dock-n-Dine in the trendy Tribeca section of Manhattan, just North of Battery Park City and south of Greenwich Village where you can enjoy hundreds of local restaurants, shops, galleries and events. Contact Liberty Landing NYC at the number above or Dock Master at Pier25@suntexmarinas.com. Hail on VHF channel 69 and the rate is \$3.00 per foot for 3 hours and \$1.50 per foot after that.

FUELING the BOAT

TARRYTOWN MARINA

East shore near new Tappan Zee Bridge. Look for Shell sign at entrance. **All new fueling station** includes float, credit card activated pumps, backup generator, all pumpout system and many other features. Gas, diesel, ice, LOCATION: Eastern Shore, 41° 4' 30" -73° 52' 1". Follow the well- marked channel starting 0.1 mile north of the Tappan Zee Bridge to marina entrance. The entrance to the marina is marked with a Shell Sign.

Tarrytown, NY

914-631-1300

www.tarrytownmarina.com

WESTERLY MARINA

(Ossining, NY)

LOCATION: Eastern Shore, 41°

9' 33" -73° 52' 10". The marina is located opposite red buoy #18 at Tellers Point, (also referred to as Croton Point).

INFO: Minimum water on approach is 10' with 8' at the dock. Ship's

Store, Ice, Drinks. Visa and Master- Card accepted.

FUEL: Unleaded gasoline (89 Octane) and Diesel (40 Cetane) available.

HOURS: Open April 15th thru November 15th, 8:30AM to 5:30PM Wednesday thru Saturday, 9AM to 3PM Sunday. The gas dock is closed on Tuesdays.

PHONE: 914-941-2203, VHF Channel 68

WEBSITE: www.westerlymarina.com

HAVERSTRAW MARINA

(Haverstraw, NY)

LOCATION: Western Shore, 41° 13' 0" -73° 58' 7". The facility is located 260 degrees off of red buoy #26. INFO: Minimum water on approach is 25' with 9' at the dock. Pump

Out (Free to members, \$5.00 for non-members), Ice, 2 Cycle Oil, Transient Dockage. Visa, Master Card, Discover and American Express accepted.

FUEL: ValvTect Unleaded gasoline (89 Octane) and Diesel

HOURS: 8AM to 8PM seven days a week. During the winter months open by appointment only.

PHONE: 845-429-2001 (Office), VHF Channel 9

WEBSITE: www.haverstrawmarina.com

NEWBURGH YACHT CLUB,

(Newburgh, NY)

LOCATION: Western Shore, 41° 30'

55" -74° 0' 27". Located 0.2 miles south of the Newburgh-Beacon Bridge.

INFO:

FUEL: Citgo Unleaded gasoline (89 Octane) and Citgo Diesel (auto- mated credited card activated fuel pumps)

This is a 24-hour credit card activated fuel pump with easy in an out access from the main channel. Deep water at the fuel dock. PHONE: 845-565-3920

WEBSITE: www.newburghycc.com

WHITES HUDSON RIVER MARINA

(New Hamburg, NY)

LOCATION: Eastern Shore, 41° 35' 1" -73° 56' 57". The marina is located opposite Diamond Reef red marker #56.

INFO: Minimum water on approach is 30' at the dock. Pump Out, Ice, Visa and Master Card accepted. FUEL: Unleaded gasoline (89 Octane) and Diesel

HOURS: May 1st thru October 15th, 9AM to 6PM Monday thru Friday, 9:30AM to 5PM Saturday and Sun- day.

PHONE: 845-297-8520 WEBSITE: N/A

WEST SHORE MARINE

(Marlboro, NY)

LOCATION: Western Shore, 41° 36' 12" -73° 57'31". The marina is located 0.6 miles north of the red buoy #58.

INFO: Minimum water on approach is 22' with 12' at the dock. Ice, soda, ships store, launch ramp, clean restrooms and picnic area with gas grills available. Visa and Master Card accepted.

FUEL: Unleaded gasoline (89 Octane) and Diesel

HOURS: April 1st thru October 30th, 8AM to 5PM Monday thru Saturday, 10AM to 5PM. Sunday (PHONE: ahead for extended hours). PHONE: 845-236-4486.

WEBSITE: www.westshoremarine.info

HYDE PARK MARINA

Hyde Park, NY

Location Eastern Shore, 41°44'15"- 73°56'6". the marina is located 1.4 miles north of red buoy #60. INFO: Minimum water on approach is 20' with 7' at the dock, ice, visa, Mastercard accepted.

Dockmaster is Keith assistant Phillip

Unleaded Gasoline 89 octane Hrs of operation Mon -Thurs 10 AM to 6 PM Friday-Sunday 9 AM - 8 PM Phone 845-473-8283

Transients Welcome.

ROGER'S POINT BOATING ASSOCIATION

(Hyde Park, NY) LOCATION: Eastern Shore 41° 46' 21" -73° 56' 45". The club is located at 62A and 62B markers.

INFO: Minimum water on approach 14' with 14' at the dock. Visa, MasterCard, and Personal Checks with NYS Driver's License ID.

Chelsea Piers on the Hudson River

(Eastern Shore in Manhattan, NY)

212-336-7873, www.ChelseaPiers.com

Located at Pier 60, West 23rd Street,

Chelsea Piers takes a day to explore so enjoy!! The Pier is a party venue hot spot. If you call the main number listed above you will get a complete listing of all that is available at the Chelsea Piers complex. Hail the marina on VHF channel 68 and the 4 hour Dock-n-dine rate is \$2.00 per foot. Not bad for access to the Chelsea Pier complex and one of the hottest areas in Manhattan.

Lincoln Harbor Yacht Club

Western Shore in Weehawken, NJ) 201-319- 5100, www.LincolnHarborMarina.com

There are a number of restaurants and grills that you can focus on within walking distance of docking your boat at Lincoln Harbor Yacht Club. There is a Dock and Dine charge of \$1.00 per foot, (4-hour limit) to keep your boat at Lincoln Harbor Yacht Club while visiting these restaurants.

The Chart House Restaurant

(Western Shore in Weehawken, NJ.)

201-348-6628, www.Chart-House.com

There was an original Chart House here

a number of years ago. It burned to the water. Now this

six-year-old restaurant is available by docking at Lincoln Harbor Yacht Club. It is an easy stroll to & from the yacht club & Chart House. Waterside dining gives way to the breath taking views of Manhattan, especially so since the new windows of the Chart House are much larger. Hours of operation are 5 to 10 PM Monday-Thursday, 5 to 11 PM on Friday and Saturday, 4 to 11 PM on Sundays. Sunday Brunch is offered from 11 AM to 2 PM. Hans Neilson, the General Manager, is very enthused and will provide you with every courtesy.

Masina Trattoria Italiana

(Western Shore in Weehawken, NJ) 201-348-4444, www.masinatrattoria.com

Located on the Hudson waterfront in the Sheraton Suites Hotel at Lincoln Harbor. Full menu of savory Italian classics and original creations available indoors or al fresco on the patio with stunning views of Manhattan. Steps from the ferry to the city and open every day with brunch on Sat and Sun.

Liberty Landing Marina



Ruth's Chris Steakhouse

(Western Shore in Weehawken, NJ) 201-863-5100, www.RuthsChris.com

Ruth Chris offers a wide range of aged to perfection steaks (U.S. Prime only), filet mignon, fresh fish, live lobsters, as well as the very best in veal and lamb chops. In their elegantly appointed restaurant, with its panoramic views of the Manhattan Skyline, guests can enjoy fine dining with selections such as fresh seafood appetizers, huge porterhouse steaks for two, a variety of potatoes and vegetables prepared to perfection, and freshly made confections. For the lobster lover, 2 1/2lbs to 5 lbs. lobsters are always on hand. Dinner is served daily Monday-Thursday 5-10PM. Friday Noon-11PM. Saturday 5-11PM. Sunday 2-9 PM.

Houlihan's

(Western Shore in Weehawken, NJ) 201-863-400, www.Houlihans.com

Houlihan's (a franchise) is a place for casual fun dining with steaks, monster salads, seafood, burgers, finger foods, and huge piles of nachos topped with everything. Appetizers include grilled chicken quesadilla, stuffed potato skins, with lunch and dinner selections such as Black Angus strips and filets, chicken fettuccine, jambalaya, stuffed chicken breast and barbecued baby ribs. Sandwich specialties like mushroom/ bacon/Swiss burgers, Brentwood Chicken with provolone and honey mustard and Cajun Chicken Grill are also available. Houlihan's is open Sunday through Thursday until 11PM Friday and Saturdays until 1AM.

79th Street Boat Basin Cafe

(Eastern Shore in Manhattan, NY) 212-496-2105, www.BoatBasinCafe.com

Located on the famous Upper West Side of Manhattan at the base of 79th Street, the docks are a short walk up to Broadway to the world famous Zabaars appetizing mecca and a host of restaurants and shops, if you're in the mood to stay water-side up a few steps from the water is the Boat Basin Cafe overlooking the marina for drinks and dining, try their delicious fish tacos. You can reach the marina at the number above or hail them on VHF channel 9, a dock-n-dine will cost you \$25 for boats 25 feet and under and \$32 dollars for boats 26 feet and over for 4 hours.

ROBS CAFE
AT THE CORTLANDT YACHT CLUB
OPEN TO THE PUBLIC
BREAKFAST | LUNCH | DINNER
FRIDAY NIGHT SPECIALS LOBSTER:
STEAK | RIBS | & MORE...
POOL MEMBERSHIPS AVAILABLE
FREE TRANSIENT DOCKING
A GREAT PLACE TO ENJOY YOUR SUMMER!
CALL 914-433-5281 OR TUNE INTO CHANNEL 16
238 KINGS FERRY RD | MONTROSE, NY 10548

*& Feeding the
Crew*



FUELING the BOAT

FUEL: Unleaded gasoline (89 Octane) with Diesel

HOURS: May 1st thru third week of October, 8AM to 7PM Saturday, Sunday and Holidays (Irregular hours on weekends based on the availability of club personnel). Opening day is May 1st and closing day is the third week of October. PHONE: 845-229-2236, VHF Channel 9

WEBSITE: www.rogerspoint.org

RONDOUT YACHT BASIN

(Connelly, NY)

LOCATION: Rondout Creek, 41° 54' 49" - 73° 59' 15". The marina

is located on the south shore of Rondout Creek, 1.4 miles west of the Rondout Creek marker.

INFO: Minimum water on approach 10' with 10' at the dock. Pump-out, store, ice, restaurant/snack bar. Visa and Master Card accepted. FUEL: Unleaded gasoline (89 Octane) and Diesel

& Feeding the Crew

Pier 701 Restaurant

701 Piermont Avenue, Piermont, NY 10968

845-848-2550 Pier701ny.com

Dining At Pier 701 Restaurant and Bar. Private Room for Catered Events.

Situated on the West Bank of the Hudson River, lies Pier 701 Restaurant & Bar, located in historic Piermont, NY. With panoramic views of the Hudson River and Tappan Zee Bridge, Pier 701 is your premier destination for our seasonal al fresco dining and Tiki Bar's happy hour specials. Come and enjoy one of Chef Denis's Mediterranean – American signature dishes and cool off with a refreshing cocktail on our Pier 701 Beach.

Our tiki bar is the prime location for happy hour, as well as our weekly band line up. Join Pier 701 every Friday and Saturday evening, as we host Rockland County's most happening bands. Summer is just beginning, make 2015 the most memorable of your life! Join us on our beach or at our Tiki Bar, while fireworks on the Fourth of July can be seen from various locations to the east, north and south on the magnificent Hudson River. Reservations for holiday events a must at Pier 701 Restaurant and Bar. Owner Denis Whitton has secured additional parking in adjacent parking lots for your convenience. By boat you must follow the markers from the main channel next to Piermont Pier, into Pier 701 Restaurant and Bar. Deep draft vessels may have a problem and it is not recommended. Chef Denis Whitton is an outstanding chef who really enjoys what he does. Try his Prince Edward Island Mussels, or his Jack Daniels Boneless BBQ Short Rib, finish it off with a wonderful dessert of Pecan Bread Pudding.

For reservations call 845-848-2550, email at Chef@Pier701ny.com or go to the website at Pier701ny.com

THE BOATHOUSE
FINE FOOD AND SPIRITS

Dock & Dine

EASY PARALLEL DOCKING ON OUTSIDE OF ADJACENT WAVE ATTENUATOR

46 WESTERLY RD, OSSINING, NY 10562 | (914) 923-6466 | OSSININGBOATHOUSE.COM

FUELING the BOAT

HOURS: May 1st thru November 31st 9AM to 6 PM seven days a week. (Fuel is available from March 15th on an irregular schedule.) PHONE: 845-331-7061, VHF Chan- nel 9 & 16
WEBSITE: www.rondoutyachtbasin.com

CERTIFIED MARINE SERVICE

(Connelly, NY)

LOCATION: Rondout Creek, 41° 41' 54" 43" -73° 59' 37". The marina

is located 1.5 miles west of the

Rondout Creek marker on the south shore.

INFO: Minimum water on approach 18' with 15' at the dock. Visa, Master Card, Discover, American Express and Gas Cards accepted. FUEL: Mobil Unleaded gasoline (89 Octane) and Mobil Diesel

HOURS: April 1st thru December 1st, 8AM to 5PM Seven Days A Week. (Evening Hours Are Some- times Extended.)

PHONE: 845-339-3060, VHF Chan- nel 9 & 16

WEBSITE: www.certifiedmarineservice.com

LOU'S BOAT BASIN

(Kingston, NY)

LOCATION: Rondout Creek, 41° 54' 4" -74° 1' 1". The marina is located on the north shore of Rondout creek 2.8 miles west of the Rondout Creek marker and opposite the west end of the Gumear Island. INFO: Minimum water on approach is 15' with 12' at the dock. Ice, Soda Machine, Ship's Store. Visa, Master- Card, American Express and per- sonal checks with driver's license ID accepted.

FUEL: Power Test Unleaded gas- oline (89 Octane) and Power Test Diesel

HOURS: April 15 thru November 1st, 10AM to 7PM seven days a week.

PHONE: 845-331-4670, VHF Channel 79

SAUGERTIES MARINA

(Saugerties, NY)

LOCATION: Esopus Creek, 42° 4' 13" -73° 56' 20". The marina is located on the south side of Esopus Creek 0.5 miles in from Hudson River. Entrance to Esopus Creek is 0.2 miles north of green buoy #91.

INFO: Minimum water on approach is 25' with 16' at the dock. Tran- sient Dockage. Visa, Mas- ter Card, Discover and American Express ac- cepted.

FUEL: Getty Unleaded gasoline (89Octane) and Diesel

HOURS: April 1st thru October 31st, Dawn to Dusk Seven Days A Week. (Fuel Service Can Be Arranged At Other Times Of The Year.)

PHONE: 845-246-7533, VHF Chan- nel 68

WEBSITE: www.saugertiesmarina.com

& Feeding the Crew

Cornetta's Seafood Restaurant

(Western Shore in Piermont, NY)

845-359-9852 or 845-359-0410 www.Cornettas.com

Located at Cornetta's Marina on Piermont

Avenue, the marina is found 0.2 mile north of the Piermont Pier. Cornetta's fea- tures fresh seafood, steaks, and Italian special- ties. The restaurant also offers an outdoor riverside patio dining under a large white tent at their "Cornetta's Cafe." During their season, April through November, the res- taurant is open daily for lunch and dinner. There is a very limited amount of dock space available for restaurant patrons. Reservations are requested for their dock. There are no fees for docking when dining. ATM on site.

The Hudson Water Club

(Western Shore in Haverstraw, NY) 845 -271-4046, www.hudsonwaterclub.com

Adjacent to the huge parking lot, on the Hudson River at the Haverstraw Marina. This is a completely rebuilt restaurant with the largest deck of any restaurant on the Hudson River and includes a fully stocked Tiki bar. There is docking directly in front of the restaurant. There are three specific menus to meet anyone's require- ments. A lunch menu, bar menu and a dinner menu. The dinner menu consists of meat and seafood dishes. Hours of operation are seven days 11:30 am to closing. Spectacular wood fired pizza a full compliment of bands Please consult www.hudsonwaterclub.com for current information!

Union Restaurant and Bar Latino

(Western Shore in Haverstraw, NY)

845-429-4354, www.unionrestaurant.net

Located at 22-24 New Main St. Haverstraw, NY 10927. This is a beautiful restored Latino style restaurant owned by Paulo Feteira, the maitre d'hotel and David Martinez, head chef. Having come from Peter Kelly's Xavier's Restaurant and Freelance Café of Piermont, the two have a combined twenty years in the restaur- ant business. The fine American style cui- sine has a Latino flare in a unique culi- nary atmosphere. The entrees are light, leaving room for a wide verity of la Carte options from appetizers to desserts. Your visit will be something to remember first by the atmosphere, (if you've ever seen a movie with a Cuban style restaurant in it here it is) secondly by the food such as Tilapia al Sarten, a panko encrusted fillet served with spinach and white beans ragout or the Vaca frita Braised skirt steak. Whether going out for an afternoons boating plea- sure or coming from the river the Union Restaurant will round out your day perfectly.

Rob's Cafe at the Cortlandt Yacht Club,

OPEN TO THE PUBLIC,

by Car or Boat. Follow the white channel markers into the entrance.

(Jet Skis and Waverunners have a separate entrance which is marked.)

Call Karen at 914 433 5281 for Transient slip assignment, which is free!

Reasonably priced salads, beer, wine, luncheon menu. Friday night specials

include one selective dish such as lobster, prime rib, etc. (call to preorder)

Sunday Morning Breakfast is from 8 AM on.

Boathouse Restaurant,

46 Westerly Rd, Ossining, NY 10562

The Ossining Boathouse Restaurant has the easiest access of anyone on the Hudson River.

Adjacent to the Shattemuc Yacht Club which has a large wave attenuator face for easy parallel docking.

Telephone 914-923-6466 Hours of operation are Monday,Wednesday,

11:30 Am to 9 P.M., Thursday,Saturday 11:30 AM 10 PM, Sunday

9 AM (Brunch is 11:30 AM to 3 PM) email is Ossiningboathouse@gmail.com

FUELING the BOAT

RIVERVIEW MARINE SERVICES

(Catskill, NY)

LOCATION: Catskill Creek, 42° 12' 43" -73° 51' 21".

The marina is located on the north shore of Catskill Creek, 0.7 miles west of green buoy #119.

INFO: Minimum water on approach is 12' with 10' at the dock. Pump Out. Visa, MasterCard, AMEX and Discover accepted.

FUEL: Unleaded gasoline (89 Octane) and Diesel

HOURS: April 1st thru December 1st, 8AM to 5PM

Monday thru Saturday, 9AM to 5PM on Sunday.

PHONE: 518-943-5311, VHF Channel 68

WEBSITE: www.riverviewmarineservices.com

HOP-O-NOSE MARINA

(Catskill, NY)

LOCATION: Catskill Creek, 42°

12' 50' -73° 52' 3". The marina is located on the south side of Catskill Creek 0.8 miles west of green buoy #119.

INFO: Minimum water on approach 12' with 12' at the dock. Visa, MasterCard, American Express.

FUEL: Mobil Unleaded gasoline (89 Octane) and Mobil Diesel

HOURS: April 15th thru November 1st, 8AM to 8PM seven days a week. PHONE: 518-943-4640, VHF Channel 16

WEBSITE: www.hoponosemarina.com

CATSKILL YACHT CLUB

(Catskill, NY)

LOCATION: Catskill Creek, 42° 12' 55" -73° 51' 55".

The yacht club is located on the south shore of Catskill Creek, 0.9 miles west of green buoy #119.

INFO: Minimum water on approach 12' with 12' at the dock.

FUEL: Unleaded gasoline (89 Octane)

HOURS: April 15th thru October 15th, limited weekend & daytime operation - based on the availability of club personnel.

PHONE: 518-943-6459 WEBSITE: N/A

HUDSON POWERBOAT ASSOCIATION

(Hudson, NY) LOCATION: Eastern Shore, 42° 15' 16"

-73° 47' 54". The yacht club is located on the east (main) channel of Middle Ground Flats opposite green buoy #133 just north of the Athens Light-house.

INFO: Minimum water on approach 22' with 22' at the dock. Pump Out, Ice, Snacks, Transient Dockage. CASH ONLY

FUEL: Unleaded gasoline (87 Octane)

HOURS: May thru October, 6:30AM to 9AM and 4PM to 6PM Monday thru Friday, 8AM to 8PM Sat-

& Feeding the Crew

Cold Spring Depot, Silver Spoon, and numerous other restaurants are located along the main street, east shore. The only docking available in Cold Spring is located Approximately one mile North of the West Point Military Academy is at the Cold Spring Boat Club. There is room for 7 to 9 boats on the outside of the floating docks with a 30-foot maximum length on vessels. No reservations are accepted and it is on a first come, first served basis. No fees are required.

However, the club asks that you register BY GOING TO THE MAILBOX ATTACHED TO THE WILLOW TREE NEXT TO THE FLOATING DOCKS AND SIGN THE REGISTER before visiting any of the restaurants or shops in town. Cold Spring Boat Club 845-265-2465. This is probably the most interesting town to make as a destination on a Hudson River boat trip. The town is loaded with antique shops and quaint restaurants.

Silver Spoon Cafe

124 Main St, Cold Spring, NY 10516,

845-265-2525

email: hussein252544@yahoo.com

This eleven year old cafe has been completely remodeled to compliment Cold Spring and the surrounding stores and restaurants!

"I have eaten at this restaurant many times over the past few years and found the food to be excellent and reasonably priced!" - John H. Vargo, Publisher. Much of the menu is exclusive to the Silver Spoon Cafe. From the Big Daddy Burger, Maryland Crab Soup, served in a large bread, steaks and fresh seafood, this cafe has it all. You might also like to try the Navajo wrap made with Cajun golden chicken, spicy chapel, and other wonderful tasty ingredients. It is open seven days a week for breakfast, lunch and dinner. At Silver Spoon we believe in fresh local foods, that's why we source our ingredients from the Hudson Valley, including Feather Ridge Farm, Hudson Valley Fresh, Coach Farm, Crown maple, Sky Farms, Starling yards and many more. All of our mews are made in house to insure the best tasting and highest quality of food.

Cold Spring Depot

1 Depot Square, Cold Spring, NY 10516

845-265-5000

Located on the Hudson River in historic Downtown Cold Spring, NY, The Cold Spring Depot offers charm and history in one convenient location. Our outstanding service and delicious food makes The Cold Spring Depot one of the best places for a family dinner or romantic night out in the area! Enjoy everything from our signature burgers, to classic comfort food in our affordable menu.

Whether you're cozied up next to the fireplace in the winter, outside on the patio watching the trains go by in the summer, or just stopping by for a hearty meal after leaf peeping in the fall, we are a year-round destination. See the sights and sounds of historic Cold Spring, "A Village that Lives in History," while you enjoy delicious food at the fun and flirty Cold Spring Depot!

By Boat, train, car or walking we can't be missed as we are the old railroad station turned into a fabulous restaurant!

The Rhinecliff,

4 Grinnell St. Rhinecliff, NY 12574

WATERFRONT DINING & DOCKAGE - BEAUTIFUL SUNSETS!

The Rhinecliff is located on the Hudson just 2 hours north of New York City.

The Rhinecliff is a Boutique Country Hotel conveniently tucked away just next door to the Rhinecliff Dock & Amtrak station, 2 miles from the Historic town of Rhinebeck. The Rhinecliff offers gorgeous river views from every angle. Our

brasserie style bar/restaurant "The Bar" at The Rhinecliff, is open daily, for breakfast, lunch & dinner from 7am, until late, and for Jazz Brunch on Sundays, featuring seasonal and local Hudson Valley produce and products. Join us for your weekend or mid-week getaway. Music offered Tues, Thurs, Fri & Sat Evenings. \$18.95 early bird special Sun-Thurs 5-6pm. Reservations recommended call 845-876-0590 visit www.therhinecliff.com

Poughkeepsie Ice House

845-232-5783

1 Main St. Poughkeepsie, NY 12601

Eastern Shore, between the two bridges, This is a historic exposed brick building with old world charm. With stamped concrete floors and 25foot ceilings, the building is reminiscent of an earlier era. The windows frame majestic views of the Hudson River Mid-Hudson Bridge, and Walkway Over The Hudson. In warmer weather, you can enjoy these views while dining on the expansive patio right on the water's edge. There is limited docking directly in front of the restaurant. Boats can be anchored to the north of the restaurant and you can dingy in at your own discretion.

All entrees served with seasonal vegetable | Available all day
 Creekstone Farms Butcher's Cut Steak herb butter, garlic mashed potatoes, Pan Seared Atlantic Salmon roasted potatoes, zucchini, summer squash, baby arugula, mustard vinaigrette. Herb Roasted Chicken garlic mashed, house gravy. Pasta Lucia grilled chicken, prosciutto, sautéed spinach, sun dried tomatoes, penne pasta, basil cream sauce.



VOTED #1 KID FRIENDLY RESTAURANT
VOTED #2 BEST BURGERS IN THE AREA

BY CAPITAL REGION LIVING MAGAZINE 2015

5 SCHONOWEE AVE, SCOTIA, NY 12302
518-393-6101 | JUMPINJACKSDRIVEININC.COM

HAGAR'S HARBOR
BAR & RESTAURANT

DOCK & DINE

MARGARITA BAR

WATERFRONT DINING! ENDLESS POSSIBILITIES!
COME BY BOAT, COME BY CAR, YOU ARE GONNA LOVE IT!

SUPERB FOOD, GREAT ATMOSPHERE, FOUR AREAS TO CHOOSE FROM TO DINE, DRINK AND BE MERRY.

10 BRICK ROW EXTENSION | ATHENS, NY 12015 | 518-444-4550 | HAGARSHARBOR.COM

DOCK & DINE

BREAKFAST | LUNCH | DINNER

Stella's II

★ PIZZERIA & PANCAKE HOUSE

518-945-1010



6 South Water Street Athens NY12015

Catering and Delivery



FUELING the BOAT

Monday and Sunday (Hours of operation can vary due to the availability of club personnel)

PHONE: 518-828-9023

WEBSITE: www.hudsonpowerboat.com

COXSACKIE YACHT CLUB

(Coxsackie, NY)

LOCATION: Western Shore, 42° 21' 43" -73° 47' 45".

The yacht club is located on the west, non-channel side of Coxsackie Island, opposite the south end of the island. Access from the south side of the channel is very limited due to a sand bar on the east side and rocks/old cars close to shore.

INFO: Minimum water on approach 8' with 14' at the dock. CASH ONLY, CLUB AND MOHAWK COUNCIL MEMBERS ONLY!

FUEL: Unleaded gasoline (89 Octane) available.

HOURS: May 15th thru October 1st, 9AM to 5PM Saturday, Sunday and Holidays (Hours of operation can vary due to the availability of club personnel)

& Feeding the Crew

Ship to Shore Restaurant, 15 West Strand, Kingston, NY, 845-334-8887

www.ShipToShoreHudsonValley.com this is the most popular restaurant on the Rondout Creek. It is celebrating its eleventh anniversary this year making it the longest running restaurant on the Rondout Waterfront District. Located just up the street from Kingston public docks. This restaurant is owned by Chef Samir Hrichi a graduate of the Culinary Institute of America and is located in the oldest restaurant building on the Rondout. Ship to Shore Restaurant combines Old New York Steak House atmosphere with Progressive American Cuisine. Voted best overall restaurant in the Hudson Valley in 2002 from the Times Herald Record. They also have two 5 star ratings from the Times Herald Record & Traveling Gourmet. 23 Zagat Food Rating. For wine lovers, every Wednesday get one half-price bottle of wine with dinner. Open 7 days a week from 11-11PM with late night bar.

FUELING the BOAT

DONOVAN'S SHADY HARBOR MARINA

(New Baltimore, NY)

LOCATION: Western Shore, 42° 27'05" -73° 47' 20" conveniently located just South of Albany, NY on the Hudson River, Marina and Fuel Dock

INFO: Easy Access Deep Water Slips, Minimum depth on approach is 10', Transient Dockage, Pump Out, Ice, Groceries, Beer, Ship's Store, Gift Shop, Certified Technicians, 35 ton travel lift, 30 & 50 amp service, Free WiFi, Cable TV, Bathroom and Laundry Room, Restaurant, BBQ Area, Swimming Pool, MasterCard, Visa, Amex and Discover accepted.

FUEL: ValvTect Unleaded (89 Octane) Gasoline and Diesel

Hours: Friday & Saturday 8AM - 8PM, Sunday thru Thursday 8AM - 6PM

PHONE: 518-756-8001; VHF Channel 16
Website: www.shadyharbormarina.com

COEYMANS LANDING MARINA

(Coeymans, NY)

LOCATION: Western Shore, 42° 28' 31" -73° 47' 21". The marina is located opposite red buoy #190. (When approaching Coeymans use Channel 9 or 16 for directions.) INFO: Minimum Water On Approach Is 7' With 7' At The Dock. This Marina usually has the lowest fuel prices in the upper Hudson River. A Huge Ship Store and an Excellent Restaurant on Premises. A Favorite for Transients Using the Channel System! Visa, Master Card, Discover and Gas Cards Accepted. FUEL: ValvTect Unleaded gasoline (Please note: ValvTect requires the use of Cimtek fuel filters that will not allow any moisture to pass thru to your boat. The filters shuts the Valvtect system down when moisture is detected!

(89 Octane) and ValvTect Diesel HOURS: April 1st thru November 15th, 8AM to 8PM seven days a week. (Marina personnel available around-the-clock for emergency fuel service.) ICE, LOCK PERMITS

PHONE: 518-756-6111, VHF Channel 9 or 16 WEBSITE: www.coeymanslanding-marina.com

CASTLETON BOAT CLUB

(Castleton, NY)

LOCATION: Eastern Shore, 42° 31' 40" -73° 45' 28". The club is located 1.5 miles north of the Castleton Bridge

INFO: Minimum water on approach is 12'

& Feeding the Crew

Downtown Cafe,

1 West Strand, Kingston, NY,
845-331-5904

www.DowntownCafeKingston.com

Located at One West Strand in the Historic Mansion House (yellow building), the Downtown Café is just seconds away from the Kingston City docks. Chef/Owner, Graziano Tecchio was born & trained in Venice, Italy. Graziano has over 25-years of cooking experience. Combining his Venetian background with modern creative cuisine. There's something for everyone at the Café with its very complete menu. An excellent brunch on Sunday mornings is offered, beginning at 9AM, held inside & outside on the lovely garden terrace. Enjoy international jazz with a cocktail at the family owned and operated friendly Café. "Very good" says Zagat ratings; New York Times gave them four stars, New York Times best desserts in 2002, Times Herald Record- 4 stars. Hours of operation: Monday-Thursday 10-10 PM. Friday & Saturday 10 -11PM. Sunday 9 -11PM. Reservations recommended.

The Anchorage Restaurant and Marina,

Eddyville, NY, 12401.

845-338-9899

www.Anchorage55.com

email: Anchorage55@live.com

Located in the breath-taking Catskill Mountain region of the upper Rondout creek. One family owned & operated for 53 years. Restaurant docks are always available. Reservations suggested. The restaurant is prided on the homemade inners, including (but not limited to) Spaghetti and meatballs, melt-in-your-mouth pot-roast, meatloaf, steaks and seafood. Dinner specials and soup daily. Friendly service is guaranteed. Kitchen hours: T-Sat. 5-9:30 PM Sun. 4-9 PM. Bar Hours M-S 3p.m.-last call, Sun. 2-11p.m.

Athens Riverfront Park,

Athens, New York,

It would be hard to find a more quaint area on the River than Athens, NY. With history, charm and the friendliness of a small town, the Village of Athens offers over 150 ft of dock to allow short-term visitors access to the restaurants and shops. The dock area consists of a length of wooden floats adjoining the concrete bulkhead of River Front Park. There are no fees or services available at dockside. From these docks it is a short walk to **Stella's Pizzeria and Pancakes** and the **Stewart Hotel**.

Stella's Pizzeria and Pancake House

Located at 6 South Water Street, Athens, NY

518-945-1010 is the perfect spot for breakfast,

lunch or dinner. Hours of operation are 7 AM until 9 PM Monday thru Thursday, Friday open until 10 PM and Sundays until 2 PM

The huge long dock across the street from Stella's, the picnic tables on the lawn and the gracious people who work at Stella's make this a fantastic stop for any boater or for that matter car that wishes to have a great meal. The original Stella's is located in Hudson, NY and has been in operation for over ten years!

The Boathouse Grille

New Baltimore, NY

Located on the premises of Donovan's Shady Harbor Marina, the Boathouse Grille provides diners with exceptional food and drink in addition to a beautiful view of the historic Hudson River. With an eye for opportunity and a passion for success, Brian and Kathy Donovan took the helm at the Boathouse Grille in 2013. Through a shared commitment to excellence, the Donovans look forward serving exceptional

FUELING the BOAT

with 12' at the dock. Do-It- Yourself Remote Controlled Mast Stepping Crane (Gin Pole), Ice, Pump Out, Transient Dockage onsite. Laundry Facilities, Convenience Store, Post Office, Library and Restaurant within walking distance. Saturdays, Sundays & Holidays during the Season they have hot meals. Visa, Master Card and Discover accepted.

FUEL: Unleaded gasoline (89 Octane) and Diesel

HOURS: May 3rd thru Mid-September (depending upon the lock system operations), 8AM-4:30PM Seven Days a week, extended hours of operation based on the availability of club personnel. PHONE: 518-732-7077, VHF Channel 16 & 68

WEBSITE: www.castletonboatclub.com

ALBANY YACHT CLUB

(Albany, NY)

LOCATION: Western Shore, 42° 38' 15" -73° 44' 53"

INFO: Minimum water on approach is 15' at the dock. Transient Dockage, Wi-Fi, Ice, Pump Out (\$5.00/use). Visa, MasterCard & American Express accepted.

FUEL: Unleaded gasoline (89 Octane) and Diesel

HOURS: May 1st thru October 22nd, 8AM to 6PM seven days a week, Hours may vary depending upon

the availability of club personnel. PHONE: 518-445-9587 (Dockmaster) or 518-465-9228 (Clubhouse), VHF Channel 9 & 16

WEBSITE: www.albanyyachtclub.com

& Feeding the Crew

a shared commitment to excellence, the Donovans look forward serving exceptional food and drink to customers enjoying a breathtaking view of the historic Hudson River. With the same passion and dedication they put forth at Shady Harbor Marina, the Donovans are looking to create a culture of fun while helping people create memories that last a lifetime.

Some samples from our menu:

Spinach & Goat Cheese Salad, topped with walnuts, tri-colored carrots and white balsamic dressing \$7 Bbq Pulled Chicken Sandwich, served with coleslaw and fries, \$12. Pizza: Braised Veal, topped with caramelized onions, mozzarella, spinach and herb garlic butter, \$13.

Yanni's Too at Coeymans Landing Marina,

16 Marina Drive, Coeymans, NY, 518-756-7033

www.YannisToo.com

Marina Phone: 518-756-6111.

Coeymans Landing Marina is located Between markers 189-191.

Welcome to Yanni's!

What's a Yanni? Yanni is a last name, the last name of Marc and Laurie, it's a restaurant, and a way of life. It's an attitude, it's cuisine, it's friendship, it's a mood, it's a fine meal. Yanni's is an experience wrapped in flavor and fun.

The Yanni family run a spectacular waterfront restaurant. Yanni's Too is located in Coeymans, NY at the beautiful Coeyman's Landing Marina.

Mariner or landlubber, dining waterfront on the beautiful Hudson River is a casual event not to be missed. Indoors or out, under cover or basking in the sun, the food and service is second to none. Come by boat or car, it's a destination you'll return to time and time again.

At Yannis the experience is always accented by great people. The Yanni staff continue to return each year and have hundreds of loyal followers. Great relationships have been built over a hot dish of calamari and a cold beer. Friendly and professional, the Yanni's staff is there to help with a quick drink or a full formal wedding. In our "house" or yours, we're here to help! Guest slips available near the Coeymans marina on a first come first serve basis! It's never too early to plan your event. Wedding, birthday, anniversary, whatever!

Your place or ours. Marc Yanni is always available to talk about your Summer events. Call now, slots fill up fast!

To book your parties, weddings, graduations early call Yanni's Too at 518-756-7033.

Hudson/Athens Ferry

Fridays and Saturdays - Memorial Day thru Labor Day

5pm - 10:30pm. Pick ups are on the hour from Hudson and on the 1/2 hour from Athens. Fares are \$15 . roundtrip, no one way fares. Coming from Hudson to Athens there are the Stewart House Bed/Breakfast Hotel with the waterfront bar. Dionosys Greek Restaurant, Crossroads Micro Brewery, Athens Diner at the waterfront Park. Coming from Athens to Hudson, there are over 40 restaurants, 60+ antique shops, a host of gallerys, several theatre groups, Hudson Opera House, Helsinki Nightclub for entertainment and the ferry is just a nice ride across the river with lovely views of the lighthouse.



FUELING the BOAT

TROY MOTORBOAT & CANOE CLUB

(North Troy, NY) LOCATION: Eastern Shore, 42° 43' 58" -73° 41' 21". The club is found along the eastern shore, 0.4 miles south of the Route 4 Bridge opposite the red buoy #1.

INFO: Deep water. Transient Dockage, Ice, Bar, Snacks. CASH ONLY, ATM on premises.

FUEL: Unleaded gasoline (89 Octane)

HOURS: May 1st thru October 1st, 9AM to 7PM Monday thru Friday, 9AM – 6PM Saturday & 1PM to 4PM Sunday. Hours may vary depending upon the availability of club personnel.

PHONE: 518-235-9697, VHF Channel 13

WEBSITE: www.troyboatclub.com

WHITEHALL MARINA

AT LOCK 12 (Whitehall, NY) LOCATION: Western Shore, 43°33' 30" -73° 23' 54". The marina is found immediately north of the end of the Champlain Canal at Lock #12 along the western shore of the Narrows.

INFO: UNDER NEW MANAGEMENT, Minimum water is 12' at the dock. Full service marina open all year round. Pump Out, Ice, Restaurant, Snacks, Soda, Pool, Transient Dockage, 50 & 30 AMP service, Showers, Bathroom Facilities, Parts. Visa, MasterCard, Discover & American Express accepted.

FUEL: Unleaded gasoline (87 Octane) and Diesel
HOURS: May 1st thru October 15th (depending upon the lock system operations) 8AM till dusk all daily. PHONE: 518-499-9700

WEBSITE: www.whitehallmarina.com

CHIPMAN POINT MARINA

(Orwell, VT)

LOCATION: Eastern Shore, 43° 48' 2" -73° 22' 27". The marina is found opposite day marker, orange triangle #76 on the eastern shore of the Narrows at Chipman Point.

INFO: Deep water. Ice, Ship's Store, Mast Stepping, Transient Dockage, 30 AMP electrical service, Wi-Fi, Shuttle to and from local restaurants and grocery store. Visa and MasterCard accepted.

FUEL: Unleaded gasoline (89 Octane), NO ETHANOL

HOURS: May 1st thru November 1st (depending upon the Champlain Canal lock system operations), 7AM to 11PM daily.

PHONE: 802-948-2288

BUOY 39 MARINA

(Orwell, VT) LOCATION: Eastern Shore, 43° 49' 19" -73° 23' 16". The marina is found opposite green buoy #73 (old buoy #39) just south of Fort Ticonderoga on the eastern shore of the Narrows.

INFO: Ship's store. Visa and MasterCard accepted.
FUEL: Unleaded gasoline (89 Octane) NO ETHANOL

HOURS: Operating season depending upon the Champlain Canal lock system operations, 8AM to 5PM daily with extended hours during the summer season from Memorial Day to Labor Day

PHONE: 802-948-2411

WEBSITE: www.buoy39marina.com

& Feeding the Crew

The Albany Yacht Club,

Rensselaer, NY,

518 465 9228 or 518 445 9587

www.AlbanyYachtClub.com

East Shore. The club is found 0.4 miles South of the Dunn Memorial Bridge.

For guests of the Albany Yacht Club there is the very popular Friday evening dinner at the club's restaurant. The dinner is a limited menu affair with entree, salad, beverage & dessert for only \$10.00. Dinner is served from 6-8PM with the lounge open from 5-1PM. Full Service Marina.

Riverfront Bar & Grill at the Corning Preserve,

Albany, NY, 518-426 4738

www.RiverfrontBarge.com Located 0.2 mile south of the Albany Railroad Bridge at the bulkhead of the Corning Preserve Waterfront Park. Riverfront is an imaginative floating Restaurant & club built on a two level refurbished barge. The popular upstairs open-air deck overlooking the Albany section of the Hudson is a casual place for food, drink, music & conversation. While the downstairs is a pleasant, fully enclosed restaurant. Imaginative light fare offerings include Seafood Chowder in a French Bread Bowl, Riverfront Specialty Crab Cakes, Scallops & many other options. The open-air deck is available Monday through Friday from 11:30AM to midnight & from noon to midnight Saturday & Sunday. Lunch & dinner is served Monday through Wednesday 11:30-10PM. Thursday & Friday 11:30AM to midnight. Sundays Noon- 10PM. At the southern end of the barge is over 100' of complementary docking. If these docks are full, dock at the City of Albany Docks & walk north through the park to the barge.

Troy Town Dock and Marina, Troy, NY.

The marina is found 0.3 mile south of the Federal Lock in Troy, just south of the Green Island Lift Bridge. There is dockage for restaurant patrons through the marina. You can call the marina at 518-272-6291 or 518-470-0461. Check with the dock personnel who are available 24 hours.

Brown's Brewing Co.

518-273-BEER (2337)

www.BrownsBrewing.com

Overlooking the Troy town Dock, this multi-story pub & brewery offers a wide range of pub style cuisine ... & GREAT BEER! The award-winning brewery, visible & operating on premise produces an excellent selection of beers, on par with the finest imports. The sampler tray is a lot of fun & worth sharing with friends. The burgers themselves are serious business, requiring two hands & carefully planned bites.

There are all kinds of great things "in a basket", old fashion steak fries, authentic fish and chips & monstrous salads. The dinner menu includes steaks, seafood, chicken & regional specialties. The second story deck, overlooking the Hudson offers a great summertime environment with an authentic beer garden on Friday evenings. Open 7 days a week for lunch and dinner. (The Revolution Hall, located next door to the restaurant is a great spot to catch some great musical acts from local favorites to up and coming talent.) Established 1959. Closed Tuesdays

FUELING the BOAT

Saratoga County north of Waterford

LOCK ONE MARINA AND SHIPYARD

(Waterford, NY)

LOCATION: Western Shore, 42° 49' 40" -73° 39' 51"

INFO: Harbor of Hospitality! 41 slips including transient dockage, Beta Marine inboard and I/O repairs. Launch ramp, restaurants and motel nearby, shuttle and rental cars available (advance reservations required). Complimentary WiFi, pumpout, cable TV, laundry, clean restrooms/showers.

FUEL: Gas and diesel

HOURS: May 1st thru November 1st during Canal operation

PHONE: 518-238-1321

WEBSITE: www.lockonemarinaandshipyard.com

SCHUYLER YACHT BASIN (Schuylerville, NY)

LOCATION: Western Shore, (use coordinates from last year's issue)

INFO: "Saratoga's Harbor" now combined with Clark's Steakhouse on premises for a great dock and dine experience, transient and seasonal dockage. Pumpout, RV and boat hookups, dump station, Wi-Fi and cable with HBO. Washers and dryers, ice blocks and cubes. Convenient to Saratoga Battlefield, racetrack and casino. Two blocks to village and restaurants. Rental cars available.

FUEL: Captain's Choice Gas and Diesel from Ray Energy

HOURS: Open during Canal Operation, 7AM-7PM

PHONE: 518-695-3193

WEBSITE: www.clarkssteakhouse.com

Waterford Riverfront



& Feeding the Crew

"Don't Forget the Canals for Great Dockside Dining"

- Pete Bardunias, President/CEO, the Chamber of Southern Saratoga County
The Chamber of Southern Saratoga County is proud to be one of the largest chambers in the State of New York with regard to the marine industry, and it is a privilege to feature some of our great member marinas and restaurants in this issue of our favorite boating magazine. For more information please visit the Southern Saratoga Information Center just past Exit 9 on the I-87 Northway, go to www.southern-saratoga.org, call us at (518) 371-3763 or email pete@southern-saratoga.org.

Hudson River From Waterford to Schuylerville

Don & Paul's Coffee Shop,

66 Broad Street, Waterford NY 12188

518-237-3447 A short walk from the Waterford Harbor Visitors Center, the restaurants of Broad Street are popular with transient boaters. Offering delicious breakfast, lunch and dinner at reasonable prices, with excellent service, this is a favorite of locals and visitors alike. A real neighborhood atmosphere, worth visiting on any canal trip.

McDonald's,

42 Saratoga Ave, Waterford NY 12188

518-235-7321 Located across the street from the Waterford Museum, close to banking and other amenities, within walking distance from the Visitors Center by following the historic 1800's Champlain Canal. Locally owned and operated by independent franchisee Roger Grout, a supporter of numerous area business and civic organizations. Drive thru open 24 hours. www.mcnewyork.com/3695

McGreivey's Restaurant,

91 Broad Street, Waterford NY 12188

518-238-2020 A full service restaurant & catering facility, with outdoor patio dining, casually elegant fine dining, and pub dining all in one great, family-owned restaurant. Culinary Institute of America-trained chef/owner, a perfect host for events including off-premise and backyard BBQ catering. Open Monday-Thursday 11:30am-10pm, Friday-Saturday 11:30am-12AM, Sunday 1pm-9pm. Live music on Saturday nights. Gift cards available for family, friends, clients and colleagues. www.mcgreiveys.com.

McDonald's,

1 Park Plaza, Mechanicville NY 12118

518-664-8844 Convenient to the city docks, shopping and nearby attractions such as the XO Tower Visitor Center, open 5:00am-11:00pm. Locally owned and operated by independent franchisee Roger Grout, a supporter of numerous area business and civic organizations. www.mcnewyork.com/4361.

Clark's Steakhouse,

1 Ferry Drive, Schuylerville NY 12871

518-695-2073 A hometown restaurant for the whole family, locally owned and operated, open for either a quick bite at the bar or a nice, sit-down family dinner. Offering steaks, seafood and a wide variety of gourmet meals. Open 7 days a week, Monday-Thursday 11AM-10PM, Friday-Saturday 11AM-11PM, Sunday 10AM-8PM. Located at the Schuyler Yacht Basin. Across the street from the 1777 site where the British laid down their arms after the pivotal Battle of Saratoga in the American Revolution. www.clarkssteakhouse.com.

Saratoga Gluten Free Goods,

176 Broad Street, Schuylerville NY 12871

518-695-6565 Even for those with food allergies, taste buds will be in for a real treat at Saratoga Gluten Free Goods, a bakery located just north of the Broad Street/Ferry Street intersection. MaryAnna O'Donnell and her family demonstrate daily that tasty food can be healthy too, and her gluten-free recipes ensure that most people can enjoy the delights served up fresh from the oven. www.saratogalutenfreegoods.com

Sweet Lou's Deli,

161 Broad Street, Schuylerville NY 12871

518-507-6013 Owned by well-known area restaurateur Louis Maggiore, Sweet Lou's features meats that are brined, cured, smoked and cooked in-house, plus a deluxe salad bar, homemade soups, unique sandwiches, fresh mozzarella, catering, "meals to go", and more. The inside will bring you back to the 1800s. www.facebook.com/che-flou23

Old Saratoga Eatery,

112 Broad Street, Schuylerville NY 12871

518-695-5555 Owner Jamie Tomas brought her culinary expertise back to Schuylerville from Florida, offering something for everyone – gourmet sandwiches, burritos, burgers, fresh salads, artisan pizza, dinners and more. Hours: Mon-Thurs 10AM-9PM, Fri/Sat 11AM-10PM, Sun 11AM-7PM www.facebook.com/oldsaratogaeatery/

Byron's Village Market,

20 Broad Street, Schuylerville NY 12871

518-695-3471 Looking for provisions for the galley? Byron's Village Market is a throwback to the old-fashioned general store with hardware, sundries, and other household items in addition to the usual groceries. Owner Byron Peregrin has been a fixture in the Schuylerville and Cambridge communities for decades, with a large group of loyal customers. Byron's has excellent values, great selection, and local produce. www.byronsvillagemarket.com

Sweeney's,

70 Broad Street, Schuylerville NY 12871

518-695-5169 Great breakfast and lunch spot. Named after the daughter of owner's Amanda and Ed Bergin, this wonderful diner offers some amazing meals cooked up by chef Courtney Lloyd. The pancakes and French toast are amazing, as are tasty sandwiches and other fare. www.facebook.com/sweeney70/

Saratoga Apple, 1174 Route 29, Schuylerville NY 12871

518-810-8034 Farm store with local produce, apples, cider and other goodies, and an awesome on-premises NYS Craft Beer & Hard Cider tasting room!! The comfortable seating space allows a nice spot to relax, and don't forget to bring your growler to take some home! Hours: Mon-Sun 9AM-6PM. Apple picking Sept-Nov www.saratogaapple.com

Old Saratoga Mercantile,

1120 Route 29, Schuylerville NY 12871

518-695-3678 A locally owned market along Route 29 heading west towards Saratoga. Old Saratoga Mercantile has a growing lineup of locally sourced products, healthy fruits, vegetable and grains, fresh meats and produce, and organic beauty products. Hours: Mon-Fri 9AM-6PM, Sat-Sun 9AM-5PM www.facebook.com/OldSaratogaMercantile



Mohawk River From Watertord to Schenectady

Stewart's Shops,

1403 Route 9, Halfmoon, NY 12065

518-371-9884 Just steps from the old canal terminal wall near the Route 9 bridge, this convenience store offers hot and cold food, ice, bait and supplies for boaters traveling on the waterway. It's the first provisioning stop past the Waterford flight headed west.

Water's Edge Lighthouse, 2 Freemans Bridge Rd, Schenectady NY 12302

518-370-5300 Offering everything from casual waterfront dining to wedding receptions, the Lighthouse is your destination of choice. Excellent food, friendly staff, beautiful venue close to downtown Schenectady including Proctors Theater, the historic Stockade District and major industry facilities. Homewood Suites hotel on site, just down the street from the Rivers Casino. Free transient dockage, plus marina for seasonal customers. Open Monday-Friday 11am-10pm, Saturday 4pm-10pm, Sunday 4pm-9pm. www.thewatersedgelighthouse.com

Rivers Casino & Resort (at Mohawk Harbor), 1 Rush Street, Schenectady NY 12305

Some of the hottest gaming action in New York, with 1150 slots and 67 table games, plus restaurants, hotels, spas and more. Close to theater, major corporations, colleges, water activities including rowing and paddling, and shopping. Transient dockage available in the adjacent harbor. www.riverscasinoandresort.com or www.themohawkharbor.com



CORNING MUSEUM OF GLASS

GLASSBARGE



MAKING WAVES THIS SUMMER

GlassBarge features glassmaking demonstrations through September, and is the 2018 signature event for the statewide celebration of the Erie Canal Bicentennial.

HUDSON RIVER WEEKEND STOPS

May 17–28	Brooklyn
June 1–3	Yonkers
June 8–10	Poughkeepsie
June 15–17	Kingston
June 21–24	Albany / Troy / Waterford

CORNING
MUSEUM
OF GLASS

CMOG.ORG/GLASSBARGE

Five to Keep You Alive

WEAR IT!

Because someone on shore loves you.



BOATING SAFETY TIPS

1. Always wear your Life Jacket
2. Take a Boating Safety Course
3. Know and follow the Rules of the Road
4. Boat Sober
5. Leave a Float Plan



Parks, Recreation
and Historic
Preservation



Scan to find a
boating safety course

WearItNewYork.com to find a boating safety course and more information.
parcs.ny.gov for information on where to boat in NYS Parks.

Sporting Clubs fought to protect Hudson Valley's rivers and streams throughout the 20th Century.



by
Violet Snow

From the *Woodstock Times*
hudsonvalleyone.com

By the end of the 19th century, when the tanning industry had clear-cut hemlocks from Catskills forests, and abandoned farms left big expanses of pasture, there were no wild turkeys in the mountains, and deer had nearly disappeared. Runoff from bare mountain slopes and pollution of creeks by the sludge from the tanneries, combined with over-fishing, had driven the remaining Esopus Creek trout high into the headwaters.

In the 1920s, when the Phoenicia Fish and Game Association was formed, followed by the Upper Esopus Rod and Gun Club and Stony Clove Rod and Gun Club, one of their goals was conservation and restoration of the land. On Saturday, April 28, from 1 p.m. to 3 p.m., the Phoenicia Library will present "Sporting Clubs, Saviors of our Catskill Rivers," by Austin "Mac" Francis, author of *Catskill Rivers and Land of Little Rivers*, and Bethia Waterman, co-founder of the Jerry Bartlett Memorial Angling Collection and administrator of the library's Angling Parlor.

While issues such as gun control, the proposed Belleayre Resort project, and the Ashokan Rail Trail tend to polarize local residents, it's instructive to be reminded that people on both sides of these controversies have always had a love of the land and nature as their primary motivation. In the bylaws of the Upper Esopus club, one of their purposes was "to promote protection of woods, waters, and wildlife." The clubs stocked the woods with game birds and the streams with fish — over 177,000 fish in 1952 alone — and they fought legal battles to restore health to the creeks.

In the 1970s, the Phoenicia club joined Catskill Waters, an organization formed to protest the lack of regulation over the release of water from the Schoharie Reservoir, through the Shandaken tunnel and into the Esopus Creek, aimed at maintaining levels in the Ashokan Reservoir, part of New York City's drinking water system. New York City Department of Environmental Protection (DEP) was opening and closing the portal according to the needs of the reservoirs, creating a rapidly fluctuating environment on the Esopus. Excessive water flow, which drove the fish into hiding, was followed by complete stoppage of water that left the fish stranded and dying along the banks.



Fly-fishing on the Esopus. Photo: Dion Ogust

In 1976, Chuck Schwartz, president of the Phoenicia club, wrote to then state assemblyman Maurice Hinchey, "I have personally rescued over a hundred wild fingerling brown and rainbow trout along with various minnows, crawfish and insect larvae. Other trout and their food were not so fortunate and were left to dry out and die in the afternoon sun...These trout were wild, and consider the tremendous amount of insect life which support these trout that were also destroyed. This food cannot be replaced and it may take years to rebuild."

After seven years of pressure, the New York State legislature passed regulations that required DEP to moderate the release of water through the Shandaken portal, preventing

the intense fluctuations that were so devastating to the fish. DEP fought the changes, but the legislation spearheaded by Catskill Waters opened the way for regulation at other reservoirs in the city water system.

One response to the degradation of the environment in the 1800s was the purchase of tracts of land by wealthy individuals. Conflict erupted between landowners and local people who no longer had access to the land they had hunted and fished for generations. When gamekeepers caught poachers on property owned by Clarence Roof in Neversink — where the Frost Valley YMCA camp is now located — sympathetic juries refused to convict the hunters. At least one trial was taken out of town, resulting in a \$70 fine for the poachers. "We think that was the start of posting property," said Waterman.

However, the wealthy landowners also formed private sporting clubs that have contributed to the preservation of rivers. The Anglers Club of New York, created in 1906, has a conservation committee. "Most of the private clubs own water," said Francis, who described how Ed Van Put of the New York State Department of Environmental Conservation (DEC) approached private landowners on the Lower Beaverkill and other streams. "He persuaded them to sell access to the water so there could be fishing on it by anyone, as long as they obeyed rules. All the clubs,

whether public or private, do feel strongly about preserving the pristineness, the sanctity, the heritage they're part of."

On April 28, Waterman and Francis will go deeper into the history of local public and private clubs, telling stories of fishermen and the activities of the clubs, especially the Phoenicia association, organized by the Breithaupts, Hillsons, and Longyears. Their talk will be recorded by Silver Hollow Audio through a grant from Catskill Watershed Corporation (CWC), which is funded by the DEP. The grant is the

third in a series that has allowed lectures on the history of fishing in the Catskills to be recorded and placed, along with transcripts, on the Angling Parlor website. "It's an effective way of archiving local history," said Waterman. In last October's program, Bob Decker described how his father caught the elusive and wily fish known as Old Bess in 1955, and Ed Kahil reminisced about growing up at Rainbow Lodge in its heyday of hosting hunters and fisherfolk. Fishing legend, author, and talented storyteller Nick Lyons gave a second presentation in December.

HUDSON WATER Club

Free Dock & Dine
Our Specialty
Live Entertainment
Every Weekend.

*Enjoy Summer For a
Beautiful Day!*

Flavorful Menus!



Dazzling Interior!

Open 7 Days a Week
for Lunch and Dinner

845-271-4046

HUDSONWATERCLUB.COM
606 BEACH ROAD
WEST HAVERSTRAW, NY 10993

AT THE
HAVERSTRAW MARINA

Beach Specials
Starting after Memorial Day

- Wednesdays
- Game Nights
- Thursdays
- Pig Roast & Seafood Bake

American Seafood Restaurant

Check out our web page for upcoming events
www.pier701ny.com

Moonlight Happy Hour-LATE Night

Mon-Thurs 10- Close
\$4 Draft
\$6 Select glasses of wine
\$6 House mixed drinks
Fri & Sat 11- Close
Sunday 9- Close
\$4 draft beer
\$6 select glasses of wine
\$6 House mixed drinks
½ price bar menu



701 Piermont Ave Piermont
NY 10968

Pier 701 is open year round and offers outdoor dining on our beach, at our Tiki Bar and 200 seat deck. Winter months we offer Supper Club shows Starring Jesse Posa as "Sinatra" and specialty wine pairing dinners. We offer two private dining rooms for all of life's special celebrations. Open for lunch and dinner. Saturday and Sunday a la carte Brunch.

Contact Vicki in Catering at pier701catering@gmail.com for Special Events



845-848-2550

DONOVAN'S
SHADY HARBOR
MARINA

boathouse
GRILLE

Welcome to the Boathouse Grille

Come enjoy food, drinks, and a beautiful
view of the Hudson River!



Dock & Dine



80 Shady Harbor Drive, New Baltimore NY 12124
518-756-7300 | BoathouseGrille.com

ALEX SALOMATOFF HAS THE ANSWERS TO YOUR BOAT QUESTIONS!



If you have a question for Master Mechanic and Owner of Alex's Marine Plus in New Windsor, NY, simply call Alex at 845-565-9199 or e-mail, AlexsMarine@aol.com

One thing that you should never forget is a boarding ladder.

Laugh, but the second you are in the water by accident or design, and suddenly you realize that you never considered a boarding ladder, could mean big trouble depending on the circumstances!

We at Alex marine, can fit your boat with the proper boarding ladder or upgrade the one that you now have so that children, seniors, and everyone in-between can get back on the boat without much hassle.

The range of boarding ladders is incredible, there is even one for dogs! Rather than you try to figure out what you need just give us a call or, better yet discuss the boarding ladder while we are doing other work on your boat. It is much easier to do it then rather than taking the boat out just to install a boarding ladder.

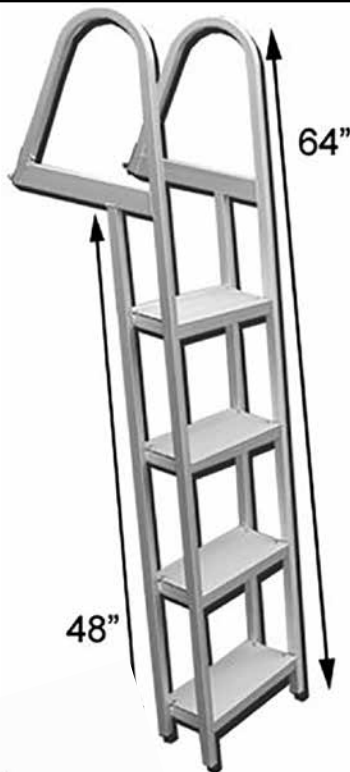

4 Steps

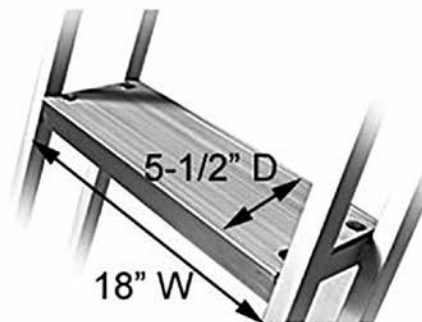

**RecPro Marine PONTOON
BOAT DOCK HEAVY DUTY
ALUMINUM 4 STEP
REMOVABLE BOARDING
LADDER AL-A4**

**Acarine-Made 4
Step Stainless Steel
Telescoping Boat
Ladder Swim Step**



Alex's Marine Plus
2907 Rte 9W Suite 200,
New Windsor, NY 12553
(845) 565-9199
alexsmarineplus.com



**Bottom Paint Special
! Coupons available
for discounts! Pick
up your SUMMER
SPECIAL FLYER**

- » All New Dustless Blasting System For Bottom Paint Removal
- » Westerly Marina All New Ships Store Featuring Yeti Coolers
- » Certified Technicians On Duty
- » 35 Ton Travel Lift
- » Fiberglass Repairs-Custom Painting
- » Sailing Supplies
- » Trailer Parts-Hitches Installed
- » Inboard-I/O-Diesel



www.westerlymarina.com | info@westerlymarina.com
914 941 2203 | Westerly Road - Ossining, NY 10562

BOAT INSURANCE

We can insure *ANY SIZE BOAT or personal watercraft*
 yachts • sailboats • speedboats • ski boats
 fishing boats • Jet Skis • jetboats



Call or e-mail for a Price Quote! *More than 5 companies to quote from.*
 Friendly professionals to answer every call and give you straight answers; no telephone menus or voice mail.



KARAS INSURANCE AGENCIES, INC.

Family-owned and operated since 1973

321 So. Riverside Ave. Croton-on-Hudson

Phone 271-5188

Fax 271-9390

cathykaras@karasinsurance.com

www.karasinsurance.com

DRIVE | DOCK | DINE



**LARGEST SELECTION OF RESTAURANTS
MARINA FACILITIES INCLUDE:**

- | | |
|---|---|
| 120 GATED SLIPS | DIVERS AVAILABLE |
| PUMP OUT INCLUDED AT NO ADDITIONAL CHARGE | BAGGED ICE AVAILABLE DOCKSIDE |
| 50 AMP POWER SERVICE AVAILABLE | FUEL, BOTH GAS AND DIESEL, 2 MINS FROM MARINA |
| WELL-APPOINTED RESTROOMS WITH SHOWERS | BULK DIESEL AVAILABLE DOCKSIDE |
| DOCKSIDE BOAT REPAIRS | NEARBY - WALK TO DINING AND SHOPS |
| PROPELLER SERVICE | CONVENIENT TRANSPORTATION |
| CANVAS SERVICE | MANY NEARBY HISTORICAL SITES |

» JET SKI DOCKS AVAILABLE «

TEL: 845.661.4914

EMAIL: INFO@RIVERFRONTMARINANEWBURGH.COM

RIVERFRONT MARINA NEWBURGH | 40 FRONT STREET | NEWBURGH, NY 12550

USA MARINA & BOAT CLUB



UNDER NEW OWNERSHIP!

USA Marina is located on the scenic Hudson River in historic Stony Point. We are a full service marina with 200 seasonal slips. We have both summer and winter land storage in order to fit your needs. Our Marina is also a licensed brokerage boat dealer and has a large selection of brokerage boats.

ENJOY 2018 BOATING SEASON WITH US!

Experts on Mechanical and Electrical Troubleshooting, Complete Isinglass Repair to Custom Canvas Fittings, Fiberglass Repair, Bottom Painting and More!

Electrical • Fiberglass • Shrinkwrap • Repower
We Store Anything...
Motor Homes / Boats / Equipment & More!

**Spring-Summer
Seasonal Boat Slips
\$60.00 per ft.**

(Utility Rate May Apply)

**Launch Ramp
\$20.00
Free Overnight
Parking**

JET SKI SUMMER RATES: \$600

36 Hudson Drive • Stony Point, NY • 845-429-0100

Your Insurance with Cathy Karas

Cathy J. Karas, Certified Insurance Counselor, President, Karas Insurance Agencies Inc, 321 So. Riverside Ave., Croton-on-Hudson, NY 10520

Many of you are experienced boaters, some having taken the Coast Guard, Power Squadron, Boater's Safety or Captain's Licensing classes. Like driving a car or riding a bicycle, once you set out on your trip, you may be on auto pilot and may not be as careful or as observant as you should be. Even if you are sure you are the most knowledgeable operator, with many years of experience operating all types of crafts, it is often the other guy or gal, that causes the problem. You have no control over what another boater might do, and as many of us have experienced, they often perform the most dangerous and unexpected maneuver at the last minute. Crossing our path, throwing up a wake, passing on the wrong side, and unsafe speed are a few examples of what you can expect. What type of boating education and insurance is required, you might wonder. Very little, at least in New York State.

You need to take a boating education class to operate a personal watercraft if you are at least 14 years old. The card certifying you have successfully completed the class has to be carried with you as the Coast Guard or Police can stop you and request to see this. They are also entitled to come on board to see

Avoiding Insurance Gaps, Tickets & Fines Operating Your Boat

if you have all the required, approved safety equipment which includes flares, flag, fire extinguisher and life vest for each passenger. But also, the website for the New York Boater's Guide Laws and Regulations states that you can operate a PWC if you have not taken the course but are accompanied by someone 18 or older who has and has the card with them. Operation of a PWC if you are under 14 is prohibited. Even scarier is the provision that a person at least 10 years old can operate a recreational boat (other than a PWC), so long as they have taken the boater's safety course, or are with someone that has and has the card with them. The thought of a 10 year old being able operate any type of recreational boat other than a PWC, who may have little to no experience is unbelievable to me.

The other issue is that unlike car insurance, New York State does not require boat insurance. You may be required to have it if you have a loan and the





lender wants to be sure their interest is protected, or a marina or boat club may require you have liability insurance in the event you cause property damage or bodily injury through your “negligence”. So, as you can imagine, there are many boats and PWCs out there with no insurance if there is no loan and not stored at a marina or club, as then insurance is voluntary. What is your exposure as an owner if you do not have insurance? You may operate your boat in a way that causes damage to another boat or dock or cause injury to a passenger on your boat, another boat, someone in the water or on the dock or shore. An electrical malfunction on your boat could set off a chain reaction causing many boats to burn. A waterskiier could be struck or a passenger on your own boat could lose their balance and fall into the water, hitting their head causing severe injury. The list goes on of the potential catastrophic incidents that could result in a law suit. A watercraft policy can provide coverage and legal defense costs for you to protect you and your assets. Think about the total of your assets, which may include a home, car(s), boat(s), investments and even a future salary that could be garnished.

What can you do about protecting yourself with insurance from the uninsured or underinsured boater? Most watercraft policies that you can buy for your own boat or PWC have a coverage called under or insured boater liability. You can usually purchase a limit equal to the liability limit you have selected for your own boat, which can either be called bodily injury liability or protection and indemnity insurance. I have not seen any New York insurance contract that provides property damage coverage, that would pay for damage to your own boat by underinsured or uninsured liability, only for bodily injury to you or your passengers. I would think it a good idea not only to buy the highest limit of bodily injury coverage not only for yourself, but also for the uninsured and under insured boaters to protect you from these hazardous boat and PWC

operators. You may not think the cost of medical attention is not a concern since you have your own medical insurance, but it is very possible at some time you may have a passenger on your boat with no medical insurance where this coverage would provide insurance coverage for medical costs if the other negligent operator was found to be at fault and with no insurance or a low limit that was insufficient to pay for the passengers injuries. This is a coverage you can buy to provide insurance for injuries to yourself and your passengers and not rely on another boater’s policy to respond, who caused the loss, where there might not even be a policy.

The presence of Coast Guard and Police Boats seems to be more prevalent since 9/11, so be aware of your speed with regards to distance to shoreline, that you have the boater’s safety course card with you if by age you are required to have taken it as I have outlined above. Be aware that a ticket or fine can appear on your New York driver’s license and then affect your car insurance premium with a surcharge, if you receive a moving violation, such as speeding.

Start the season safely making sure you have the proper education requirements fulfilled, an insurance policy with adequate limits of coverage and knowledge of the speed limits and rules of safe operation!

Cathy J Karas, President, Karas Insurance Agencies Inc, 321 South Riverside Ave, Croton-on-Hudson, NY 10520. I can be reached by phone (914-271-5188) or email (cathykaras@karasinsurance.com) for any questions or personal or commercial insurance quotes.

Disclaimer: This article is for informational purposes only. Contact the NY State web site parks.ny.gov for the Boater’s Guide rules or your insurance agent or company for information on your own policy.

I'm an "airplane nut: I've loved airplanes ever since I can remember. I like to see them sailing through the sky, read about them (I have a LOT of books) and look at pictures of them, and go to air shows to look at and take pictures of them (An interesting aside: I once took a flying lesson in a small light plane, probably a Cessna. I expected to love it, but did not like it at all: go figure.).

I went through a "train thing"—Lionel, HO gauge, real trains—for a while, but that has faded. And, as a teen-ager, with my first driver's license, I became a "car nut". I still am—I've never owned a "cookie-cutter" "plain jane" car—my cars, from the get-go, have all been "special" in one way or the other: from a dual four-barrel carburetor Plymouth Fury (110 miles-per-hour in second gear through the drag strip traps) to a 56.5 miles-per-gallon made-by-Mercedes Smart Car with trick after-market stainless steel dual pipes.

Back to airplanes: in all my readings, and personal encounters, anyone who joins the US Air Force and wants to fly—surprise, surprise—wants to fly fighters, be they P-51 Mustangs back in the day, or F-100 Super Sabres, or F-22's. But, everybody, for a lot of reasons, isn't qualified to fly fighters. So, in all my readings, and personal encounters, many of these folks end up in the next best thing: in the left seat (or right seat) of bombers, lumbering along, while the spiffy fighters do S-turns up above.

I don't think I've ever read of anyone, or heard anyone say, that they always wanted to fly cargo/transport planes. "Boy, I've always wanted to fly a C-82 Flying Box Car..."



And, how many C-82 Flying Box Cars have you ever seen at an air show, or in a War Birds book????? But...fighter planes are glamorous, bombers do what has to be done to win wars, but if it wasn't for the unsung workhorse transport planes, back there behind the scenes, none of the bullets, bombs, or beans get flown to where they have to be.

Over the past several years we've passed Dover Air Force Base in Delaware many many times on our way to Maryland and back. For a long time there were lines of huge, grey C-5A's parked on the tarmac. They've been replaced by huge, grey C-17's. And, at the southern end of the base there's a big collection of older cargo/transport planes parked outside a big Air Mobility Command Museum hangar.

I do have a bit of a history with modern-day transports: Kath and I once flew to Quantico in a LOUD Marine Corps KC-130 Hercules (gotta love those Herks!), and I once sat in the radio operator's seat in a Stewart Air Force Base 105th Airlift Wing C-5A, heading for

"I've Always Wanted To Fly A Flying Box Car"

by **Ralph J. Ferrusi**

Get in touch with Ralph at: rjferrusi@frontiernet.net



Boeing KC-97L
Stratotanker.



KC-135E Stratotanker



A-26C Invader

Lackland AFB, a Brigadier General in the left seat, a full bird Colonel in the right. I was like a kid on Christmas morning when they pushed those throttles forward on Stewart's LONG runway.

Back to Dover: usually we were in a rush to get to Maryland, or, back home. But one day we turned off Exit 91 on DE1/US 113 and followed the brown museum signs. We passed a T-33A jet trainer inside the entrance (admission is FREE), and after we parked I practically ran out of the car towards the planes on display on the tarmac. There are "over 30" airlifters, refuelers, jets, helicopters, and gliders, a one-time Vice Presidential jet, and a B-17G and C-47.

We passed a maintenance shed on the way, and poked our noses inside. Right by the door was a Rolls Royce Merlin V-1650 P-51 Mustang engine; I'd never seen one outside an airplane. I touched it; I was, in a word, thrilled: to me, the North American P-51D Mustang is the fighter plane of all time. I've actually dreamt that I was up there flying a P-51D (a good thing the dream ended before I had to figure out how to land it: where was the landing gear switch; the flaps; the throttle???) . Not knocking the C-82's or C-119's, but I've never dreamt of being in the left seat of a Flying Boxcar.

Hey, isn't that a C-97??? And a C-119??? A HUGE C-124 Globemaster!!! Wow, an A-26 Invader! A C-54, and a Lockheed Super Constellation. Kath probably thought I had gone nuts, all wide-eyed and snapping pictures... of transport planes!!!

We finally went inside the hangar. Yah just gotta love poking around inside a B-17, wondering what it could possibly be like in the ball turret, and for the cramped, lonely tail gunner. Over 12,000 B-17 Flying Fortresses were produced during World War II. More B-24's were made, but the B-17's (think Memphis Bell) always got the press. At the time of our visit, only about 40 B-17's existed in museums; only about a dozen were still flying.

The B-17G in the Dover museum, Serial Number 44-83624, has an interesting history. It was one of the last B-17's on active duty in the Air Force. In 1957, it was retired to the Air Force Museum at Wright-Patterson AFB, Ohio. It was disassembled at the museum, and flown to Dover in a C-5 (!) in 1989. It was restored over a seven year period as the 381st Bomb Group "Sleepy Time Gal". It's a beauty.

Facing it is an olive drab C-47 with black and white "invasion stripes" on the fuselage and wings. The C-47 is a military version of the Douglas



**Douglas C-54M
Skymaster**



C-124A Globemaster II



B-17 Flying Fortress

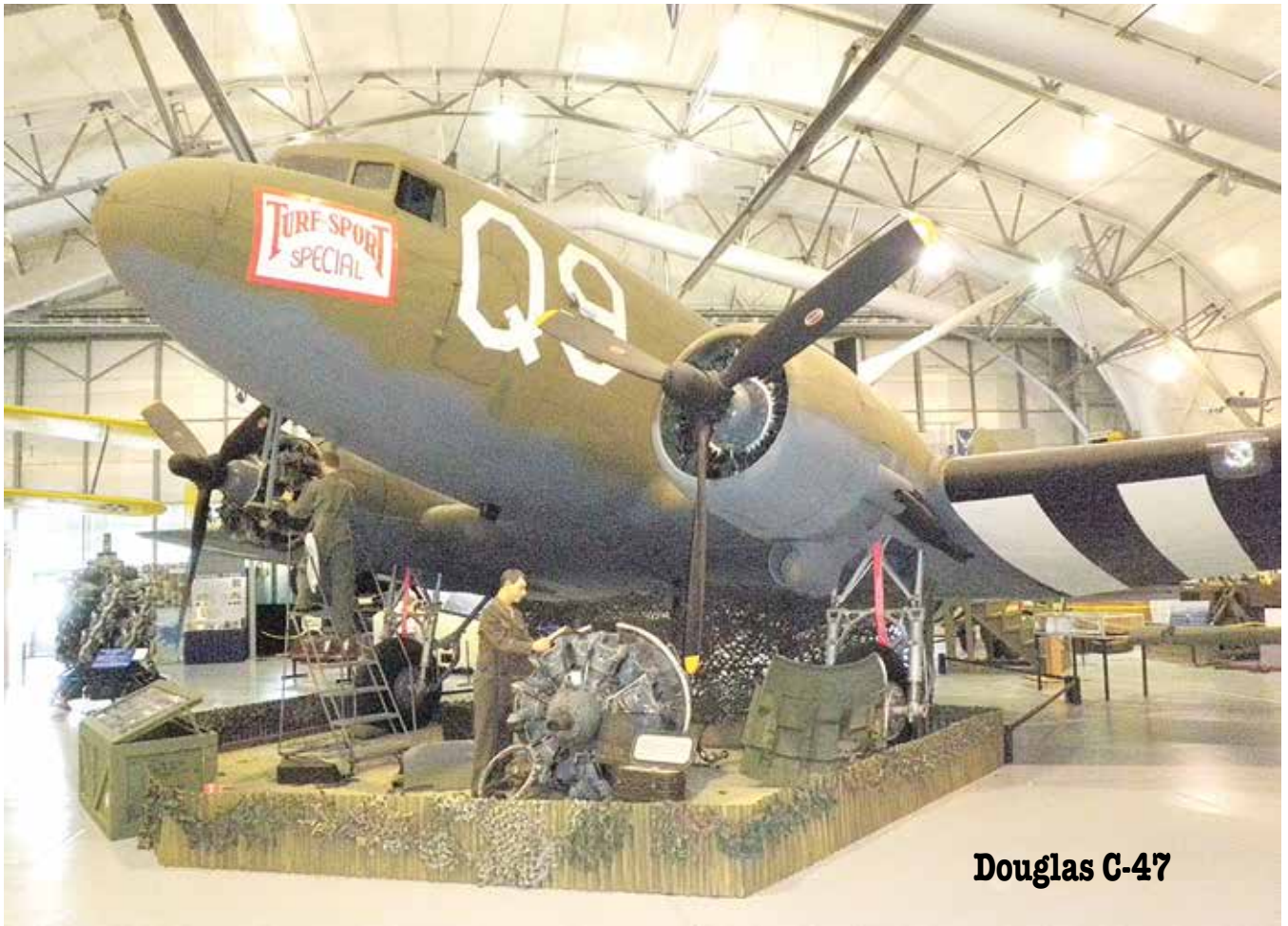

Douglas C-47

DC-3 airliner, that first flew on December 17, 1935. The first C-47 flew on December 23, 1941, and 10,174 were built. Some DC-3's/C-47's are, amazingly, still in service today, particularly in the Southern Hemisphere.

The AMC museum C-47A Skytrain, Serial Number 42-92841, was rejected by other museums as "beyond salvage". It has been restored as the World War II 61st Troop Carrier Squadron "Turf & Sport Special". On D-Day, June 6, 1944, it delivered 82nd Airborne Division paratroopers to St. Mère-Église.

This was a great visit, and I was sooooo glad we finally stopped in, and paid homage to the Air Mobility Command. If you're an airplane nut and are ever down that way, pull over: you'll be glad you did.



The Rolls Royce Merlin V-1650 P-51 Mustang engine.





**B-17 Flying Fortress. Restored as
“Sleepy Time Gal”**

The Air Mobility Command Museum in Dover, Delaware is dedicated to military airlift and air refueling aircraft and the men and women who flew and maintained them. It has the largest and most complete collection of fully restored U.S. military cargo and tanker aircraft in the Eastern United States.



PANCO PETROLEUM CO.

800.477.4645

Open 7 days a week: 7am to 7pm

3 types of fuel: 89 Octane | 92 Octane | Premium Diesel



23 GRASSY POINT RD, STONY POINT, NY 10980
WWW.PANCO.COM

LATITUDE: 41° 13' 28.1845"
LONGITUDE: -73° 57' 54.9767"



**Newburgh
Yacht Club**  

(845) 565-3920
WWW.NEWBURGHYC.COM

THE GREAT NEWBURGH YACHT CLUB

We have it all in 2018...



NEW IN-GROUND POOL!

- CLUB HOUSE WITH SHELTERED PATIO/GRILL AREA
- NEW FLOATING DOCKS
- JET SKI DOCKS
- 25 TON TRAVEL LIFT
- RESTAURANT ON SITE
- FUEL DOCK 89 OCTANE AND DIESEL
- BOAT SLIPS FOR STRIPER FISHERMEN
- SEASONAL SLIPS



VIST US ON FACEBOOK

1 PARK PLACE

SUITE 1, NEWBURGH NY 12550

Planning an Upstate Trip? Get Some Local Knowledge First!

Lock One Marina and Shipyard (461 Hudson River Rd, Waterford, NY 12188, (518) 238-1321, www.lockonemarinaandshipyard.com) offers a laid back, quiet place to stop just a short way into the Champlain Canal, with professional mechanics and boat hauling services available, plus fuel and other amenities. If you're looking to meet some new friends and experience the canal lifestyle, you might wish to keep your boat here for a weekend...or a lifetime!

by **Pete Bardunias** *President/CEO, the Chamber of Southern Saratoga County*

Trips on the canal system can be a lot of fun, especially this year when celebrations are planned to commemorate the 100th anniversary of the modern Canal System (1918-2018). There are festivals galore all year long, plus great accommodations for your boat, (or your family if you wish to get off the boat for a day or two), fine dining, quick meals and ice cream, recreation venues, and more. The key to finding any/all of the above is to obtain advice and information from the locals who know their area best and are eager to share their insight with visitors!

If your cruising plans involve the Hudson River/Champlain Canal or the first twenty miles or so of the Mohawk River/Erie Canal, you're in luck. The Chamber of Southern Saratoga County (CSSC), its members and local partners maintain some great displays of



Locals all know the best place to get sweet treats in Mechanicville is Park Avenue Confectionary (221 Park Avenue, (518) 664-3066, www.parkavenueconfectionary.com). Here owner Rebecca Tollisen shows off some of her fall creations. Stop in to keep your sweet tooth satisfied all year long!

Local knowledge comes in handy when big changes happen along the waterfront. Jason Young (right), pictured with the author, made a big move over the winter, purchasing the Schuyler Yacht Basin and bringing Clark's Steakhouse right to the shoreline (see dock and dine section for more info). Recently completed, both the Yacht Basin and Clark's are open and ready for your visit!



information in Clifton Park, Waterford, Mechanicville and Schuylerville, much of it also available online. If your plans involve trailering the boat up, you can even stop at the Southern Saratoga Information Center at the Clifton Park Rest Area (between Exits 9-10) on the I-87 Northway. With local knowledge, you'll know which restaurant serves your favorite or is open later, where the nearby hotels are, how to find trails, historic artifacts, and other services. Your trip will come alive as you experience the hidden stories not found in most history books about the Battle of Saratoga, the Industrial Revolution or the Information Age. You'll catch fish in secluded, quiet waters or explore a trail that once carried Sal the Mule and his compatriots for hundreds of miles, carefully maintained over a century after its decommissioning. To get started, visit www.southernSaratoga.org or call the Southern Saratoga Information Center at (518) 371-3763. You can also visit places like the Waterford Harbor Visitors Center, the CSSC's Clifton Park and Waterford offices, the Mechanicville City Dock bulletin board or the Schuyler Yacht Basin. There are plenty of opportunities to explore upstate waters and communities in 2018!

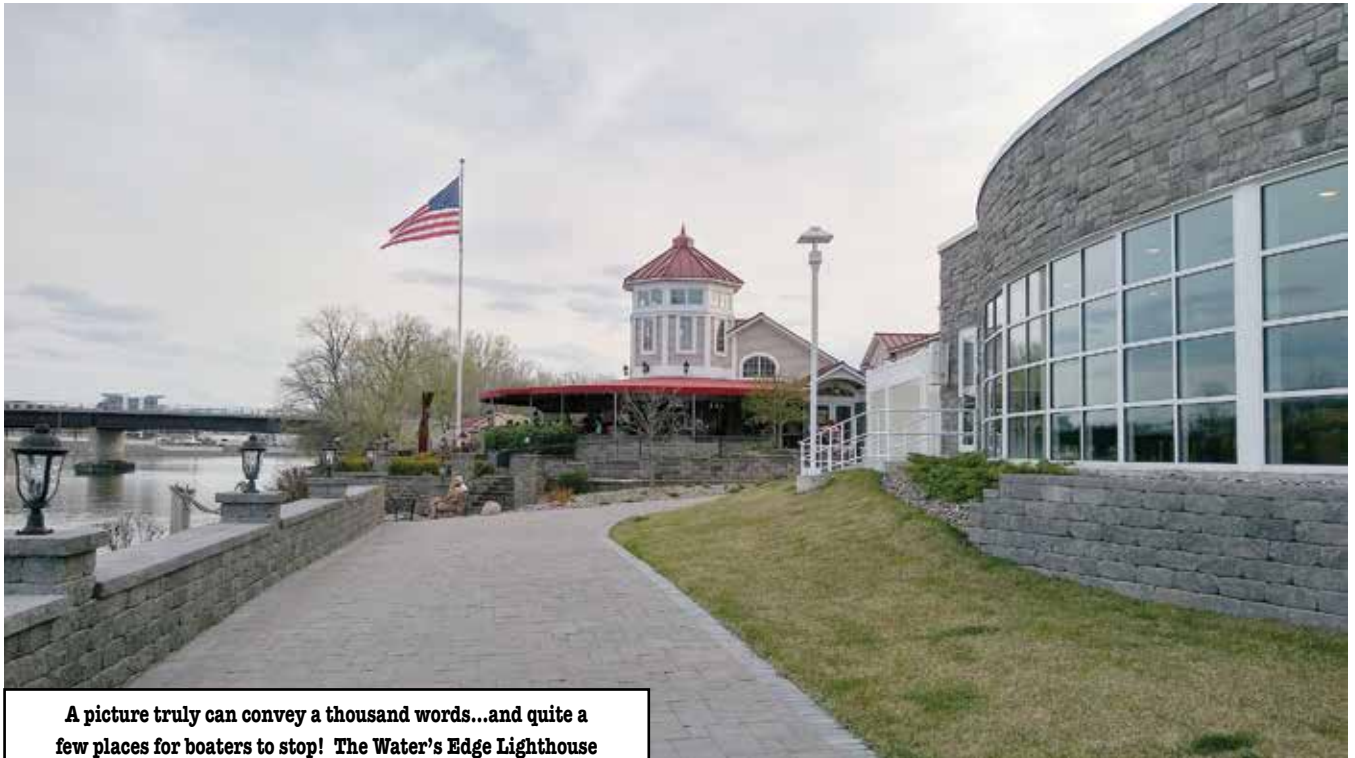

A picture truly can convey a thousand words...and quite a few places for boaters to stop! The Water's Edge Lighthouse Restaurant (2 Freemans Bridge Rd, Glensville, NY 12302, (518) 370-5300, www.thewatersedgelighthouse.com) is a wonderful place for an evening meal, with an added bonus - the new Homewood Suites hotel (foreground) and the massive Rivers Casino / Mohawk Harbor complex just behind the bridge. Visit www.southernSaratoga.org or call (518) 371-7748 for more information about these facilities.

Local knowledge is best viewed through the eyes of the people who make their homes and their living along upstate New York's inland waterways. Here Captain Marla Hodge pilots the paddlewheel tour boat Caldwell Belle (www.mohawkmaidencruises.com) up a peaceful stretch of the Hudson near Schuylerville. Whether you visit this area aboard your boat or someone else's, there's plenty to see and do here!



2006 • 12 Years with Dr. Gel • 2018



Ask Dr. Gel

by Dave Weakley



Dave Weakley is the owner of American Boat Restoration and has been helping Northeastern boaters keep their boats in fine trim and good repair for over 40 years.

“Email me or call me with your questions! I’ll be happy to help you out”
americanboatrestoration.com / email: boatrepair@aol.com / Office: 413.665.7424 / Cell: 518.577.7799



Snake Oil, Floor Wax, Shine Glo, Clear Coat

Frequently people call me about fade on their boat and want the gelcoat to look shiny and nice again. There are many variables and steps involved in order to get gelcoat looking good again. You will not find a remedy to get rid of fade at a big box store! Most importantly the popular boat related forums relating to color restoration are often terrible advice!

A boat, very well known and well built in 2006 was brought to me for color restoration and gelcoat repairs. The gelcoat colors on it are mainly white with black accent stripes.

Above the rub rail the narrow black gelcoat faded and chalked to a grey and was in badly need of color restoration. The owner told me he compounded and buffed it each year but it never really looked good and the fade always came back quickly. He also had a boat repair facility try to get rid of the fade and improve the gelcoat on it as well. Photos show their process didn't work very well.

I began to examine the surface closely and noticed paint brush like strokes on the surface and thought some type of substance was applied for a quick fix. As the boat owner watched I compounded a small section to see if I could get the color back. As I continued a layer of white oxidation began to disappear revealing the original color. The

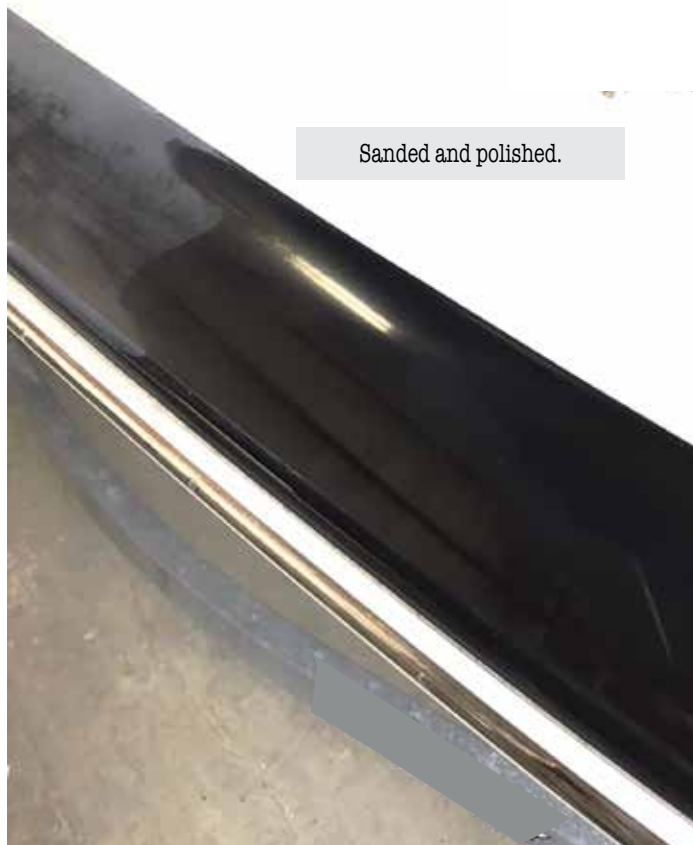

brush strokes diminished but they and a fine misty discoloration remained. The compound was not aggressive enough so I went a step further and wet sanded the section using a high quality 1500 grit sand paper. The nice rich gelcoat came back. It took sand paper to get the mess off the boat. I determined some type of "snake oil" solution I call it was applied and I know what it is. All I can say is that it begins with the letter "V". I tested this "V" product many years ago and determined it was nothing but a short lived mask. It may look good for a few weeks but it's truly garbage and advertising misleading. By applying this junk it added an extra expense to the boat restoration.

GELCOAT COLOR RESTORATION

Why does gel coat fade and chalk?

Gelcoat has a porous surface and fades because of UV sunlight penetration.

Degrees of fading will vary depending on color; darker colors, e.g.; red, maroon, green, dk. blue all have large amounts of pigment will fade faster than lighter colors. White and lighter tone gelcoat will often appear "chalked" after years of sun exposure.

Can gelcoat be restored to its original color? In most cases gelcoat color can be restored. I suggest doing

it rather than re-gel coating because remember gelcoat is suppose to be between 10-18 mil thick. An excessive amount of gelcoat is likely to crack, aka crazing & spider cracking.

What's the procedure?

The degree of fade will determine the method of gelcoat restoration. Here is the basic process.

I test spot an area starting with a professional grade gelcoat compound. If that does not remove the fade I will wet sand using a machine with special 1500 grit sandpaper specially designed for fine finish sanding and use a sanding block for hard to get small areas. During the process the sandpaper is completely saturated with water. If the fade is still present after testing with 1500 gt., I will then use the special 1000 gt wet sandpaper. If I use 1000 gt I have to go back over the area using 1500 gt. Side note- I will not use any coarser than 600 gt. paper. I work in an area 1 sq. ft at a time all the way around the boat being very consistent on how much sanding is done. The gelcoat must be sanded evenly otherwise the boat will look like a leopard. If 600 gt is removing the fade, 1000 gt is used next. Depending on finish desired I will use 1500 and 2000 gt . Final applications are professional grades of compound, sealer glaze to seal pores and good UV protecting wax.

In a situation when gelcoat is so deeply faded that it cannot be restored, a regel is done. The preparation for new gelcoat requires some of the existing gelcoat to



Restored original gelcoat surrounded by oxidation.

be removed to stay within desired gelcoat mil. This process can run into big dollars as it is extremely time consuming!

As I have said many times the best way to protect gelcoat and prevent fade is to keep it waxed with a good UV protecting wax and cover it as best as you can. I recommend that the canvas cover fit over the rub rail. Any unprotected gelcoat left exposed to the sun will oxidize.

The tempting "easy restoration fix" will cost you more money in the end!

“Dr Gel is ready to go boating! Are you?”



MORE POWER
TOWING CAPACITY: 5,800 TO 9,800 LBS
TO YOU!

Hudson Cadillac Buick GMC Has What You Need!



Like Us On... Follow Us On... hudsongm.com
@HudsonAutoGroup
Route 9 At The Poughkeepsie Galleria
Sales 888-245-5589 • Service 866-602-0867
Habla Español Estamos Para Servirle

Visit

boatingonthehudson.com

**for
the
latest.**

RE-POWER

When it comes to Repower, Experience Counts! Call us to discuss your repower options. Experience the fuel savings, reliability and lower maintenance our expert repower team can provide.



Summer
2018
SPECIALS!

Riverview Marine Services Inc. Our 41st Year!

103 Main St. Catskill, NY 12414 518-943-5311
www.riverviewmarineservices.com

Lou's BOAT BASIN

BOAT SLIPS AVAILABLE

GET YOURS WHILE THEY LAST!

FAMILY OWNED AND OPERATED SINCE 1952

DOCKAGE :

\$40- \$50.00 PER FT., WATER AND ELECTRIC INCLUDED, BATHROOMS, CALM WATERS, BEAUTIFUL VIEW, NEARBY BEACH AND WATERFALL GREAT FOR ANCHORING AND SWIMMING!

GAS :

WE ALWAYS TRY TO KEEP OUR PRICES AS LOW AS POSSIBLE, OUR SEASONAL DOCKING CUSTOMERS GET A DISCOUNTED RATE (WE ALSO HAVE ETHANOL FREE GAS)

SHIP STORE :

ICE, COLD DRINKS, BOATING SUPPLIES, PARTS & MUCH MORE FOR YOUR LAST MINUTE NEEDS

STORAGE :

HIGH AND DRY SOLD AT REASONABLE RATES

Located on the Historic Rondout Creek

944 Abeel Street Rt. 213 | Kingston N.Y. 12401

CALL NOW - 845-331-4670

PRECISION

PROPELLER REPAIR

We Repair Propellers To Mint Condition...

Without It Costing You A Mint!

**We'll Get You
Back On The
Water FAST!**

- Full-Service Propeller Repair
Bronze, Stainless Steel, Aluminum
- Like-New Performance at a fraction of the cost.
- All Makes & Models
New, Used, Reconditioned.
- Easy Drop-off and Quick Turnaround
- 25 Years of Experience

Also: Rudder Straightening, New Shafting, Skegs Replaced
Cutlass Bearings, Struts, Hubs and Couplings
Proudly Serving Over 150 Marinas in the Tri-State Area

Lake George Service



78 Bridge St. Newburgh, NY 12550

845.562.3880

www.precision-props.com



Learn All Aspects of Minor Gelcoat Repairs.

American Boat Restoration

GRINDING - MIXING - CATALYZING - SPRAYING - SANDING - BUFFING

Tips on best tools & materials to use

Training in Northampton, MA.

Instructor - Dave Weakley,

Boating On The Hudson & Beyond magazine's "Ask Dr. Gel"

Certified professional with over 40 yrs experience

*This is the perfect opportunity to become skilled at
minor Gelcoat, Fiberglass & Polyflake repair.*

americanboatrestoration.com

tel 518.577.7799 • 413.665.7424

email- boatrepair@aol.com

"Give me a call; you have nothing to lose and everything to gain"

P&T Surplus

TOOLS • TARPS • FACTORY SURPLUS

TARPS!

• Economical Blue & Heavy Duty Green/Silver

GREAT PRICES

WE SHIP DAILY

www.ptsurplus.com

845-338-6191

198 Abeel St. Kingston, NY

WESTERLY MARINA Inc.

Westerly Road, Ossining
New York 10562



914-941-2203

2008 33' Crusier Inc Twin 8.1 Inb's 7.5 Kw Genset \$92,000.00
 2001 23' Searay 225 Weekender Merc 5.0L Fully Equiped \$10,500
 1986 25' Tanzer Shoal Keel Roller Furler 9.9 4 Stroke Merc \$7,500.00
 1988 27' Searay Sundancer 268. Twin 4.3L Merc O/D's \$12,500.
 1995 Crusiers Aria 2420 Volvo Duoprop 7.4 L V8 Low Hours \$7,999.00

New Merc O/B's	List Price	Sale Price
2.5M 4 Stroke	\$1,040.00	\$832.00
3.5ML 4 Stroke	\$1,240.00	\$868.00
4M 4 Stroke	\$1,575.00	\$945.00
4ML 4 Stroke	\$1,595.00	\$1,165.50
5ML 4 Stroke	\$1,800.00	\$1,260.00
6M 4 Stroke 1	\$2,035.00	\$1,221.00
8ML 4 Stroke 2	\$2,340.00	\$1,404.00
9.9 ML 4 stroke 1	\$2,615.00	\$1,380.00
9.9MXL 4 stroke 1	\$2,865.00	\$1,900.00
9.9 EL 4 stroke 1	\$3,075.00	\$1,845.00

Used Outboards

90 ELXPT Merc 2 Stroke 2005 ----\$4,000.00
 9.9 EL 2 Stroke 2002 Merc -----\$1,500.00
 9.9 4 Stroke 2009 Merc -----\$1,300.00



NEW/USED

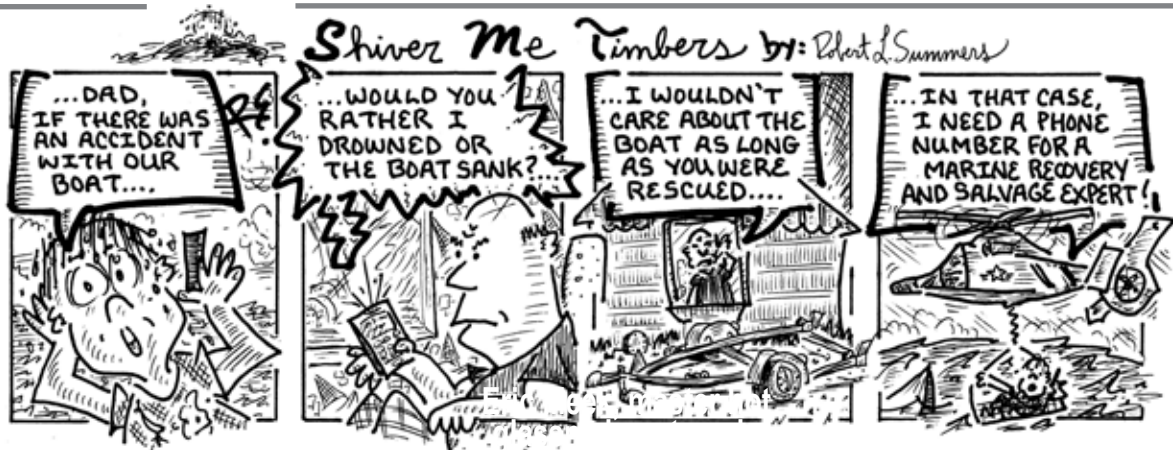

500 YARDS SOUTH OF THE DUNN MEMORIAL BRIDGE, OR 1.5 NM NORTH OF MARKER #221 ON THE EASTSIDE OF THE HUDSON RIVER IN RENSSELAER, NY

ALBANY YACHT CLUB

JUST MINUTES FROM DOWNTOWN ALBANY, THE EMPIRE STATE PLAZA, CULTURAL EDUCATION CENTER, TIMES UNION ARENA & AMTRAK

www.albanyyachtclub.com

NY CANAL PERMITS
 WI-FI • CABLE TV
 TRANSIENT DOCKAGE 17' DEPTH
 GAS • DIESEL
 PUMP OUT SERVICE
 HOT SHOWERS
 LAUNDROMAT



AMERICAN EXPRESS - DISCOVER - MASTER & VISA CARDS ACCEPTED

FOR RESERVATIONS CALL (518) 445-9587 FROM 8 AM TO 8 PM OR VHF CHANNEL 16



ALUMINUM BOATS

Nick Roberti's Marine

Kingston, Ny 845-336-8111
Visit Our Website: robertiboats.com
New Aluminum Boats
Crestliner & Polar Kraft Jon And V-bottom 10'-21'
In-stock On Sale
Trailers Available

Stewart Marine

Alumacraft • Meyers Boats
New & Used Semi-Vs and Jon Boats
Free Delivery Home or Reservoir
Jack Stewart 845-277-3143
www.stewartmarine.com

BED AND BREAKFAST

BRICKTOWN INN B&B, Haverstraw, NY

Just one mile from Haverstraw Marina in walking distance to some great dining. Victorian elegance in a restored brick home with all modern amenities - we'll even pick you up from your boat! bricktowninnbnb.com
112 Hudson Ave 845-429-8447

BOAT BUILDERS

www.constructivehands.com

BOATING CERTIFICATION

CAPTAIN TRAINING IN CAPITAL DISTRICT

Locally owned USCG-approved
OUPV/Master Information/Eligibility
Schedule/Fees (518) 312-9041
contact@nav-ed.com

NYS /NJ Boating Safety Certificate

Courses Over 3000 graduates taught by USCG Captains You come to us OR we bring the class to you (845)942-7245 or seasearch4@yahoo.com

BOAT CHARTERS

Fins & Grins Captain Bob Lewis •

24 ft. Seaswirl Hardtop • Latest Electronics
Supplies all boat and tackle.
518 943 3407 • 518 929 1888
Lunkers12@verizon.net

Striped Bass Fishing Charters

On the Hudson River & Lake Ontario
Aboard the "Polecat" 6 hour Trips AM or PM
For Reservations call 973-508-3319

For Business-Family-Friends Private Yacht
Charters Aboard A Fleet of Luxurious Vessels
Accommodating 25-350 Savory American Fare
Breathtaking Views Call: Bob Zampino 845-304-3260
email: rzampino@verizon.net

Totally Hooked Charters

Capt. Nick Lange, Ph. 845-594-3372 • Hudson River
Striped Bass. April-May-Kingston. June-Sept. trips
run out of Mexico Bay, Lake Ontario www.hudson-
riverstripers.com.
thcharters@hotmail.com

Ace Charters

Hudson River Striper Charters
out of Coeymans Landing, NY
28 ft. 2009 Baha Cruiser
call 413-346-7675
www.acecharters.com

SERVICES DIRECTORY

Reel Addicted Charters & Guide Service

Hudson River Striped Bass (April-May)
Lake Ontario Salmon/Trout (June-Sept)
25' Robalo & 31' Rampage w/latest electronics.
All necessary equip. provided
For info. Call Capt. Mike Ford 845-594-3301
Email: reeladdictedfishing@gmail.com

Going To Myrtle Beach?

Try a different kind of golf. Gulf stream fishing. Fish aboard a fully equipped 26 ft Seahunt center console. Targeting, Tuna, Dolphin, Wahoo, Bill-fish and many more species of game fish.
Call Capt. Dan at 914-760-6452
or visit www.careyoncharters.com

Rondout Cruises Offers Private Luxury Cruises Of The Hudson

Aboard A Beautiful 43' Motor Yacht. 3 Hour Cruises For
Up To 6 Passengers For Only \$359 Call (845) 339-0180 or Online Rondoutcruises.com

'Charter One'

Fish in style and comfort on a 29' Luhrs Tournament.
USCG licensed and fully insured.
Now booking 5 hour trips out of Albany for Spring
2005, Captain Bob Wason, Tel: 518-369-0497 • email:
rwason@nycap.rr.com

Festiva Boat Charters

Heated and Air conditioned
weddings, Bar, Sweet 16, Corporate
Unique yacht, Money Saver
Bar mitzvah, sweet 16 parties, corporate
973 626 1846
email anthonytromal@gmail.com

Sunset Cruises & Fishing Charters

USCG Certified Capt. C.J. Bouchard Licensed &
Insured April-October Hudson River,
Saugerties NY 845-246-1514
email: bouchard12477@aol.com

STORAGE

Riverview Marine Services Inc. Catskill

Complete Marine Service And Supply
Center Inside And Outside Storage
Spaces Still Available. Powerboats To 36'
518-943-5311

BOAT HANDLING INSTRUCTION

BOAT DELIVERY SERVICE

Captain Rob Lewis, 30 years experience, easy going,
day and night operation, Hudson River, Long Island
Sound, Atlantic Ocean, Any Boat, Any Time. Priced to
fit your budget.
Call 914-489-4848

Captain Bob Frederick, USCG Licensed 100-
Ton Master. Pro Captain/Crew services, Delivery,
and experienced Captain Coaching (Docking,
Navigation, Instruments, Radar, Float Planning).
Any Power vessel. Hudson, Canals, Champlain.
Budget-friendly rates. 845-551-1396

Double AA Captain Services

Captain Joe Malgieri
US Coast Guard Certified Master Captain Specializing
in Navigation and
Boat Handling (914) 522-9403
captainjwm@optonline.net

BOAT PARTS & SUPPLY

AMSOIL PRODUCTS

Demand the best lubes and filters for your vessel. John
Pagliuca Amsoil Marine Lubrication Specialist
914-402-4239800-385-3783 lubedealer.com/johnpag

ACTION MARINE SERVICES

Marine Parts & Supplies
Propellers - New & Reconditioning
Upholstery & Canvas Supplies
Foam Cut-to-Order • Trailer Parts & Repairs •
actionmarine@optonline.net
845-721-2146

BOAT RENTALS

Saugerties Marina

Kayaks, Canoes, Runaboats Poontoon Boats
By The Hour, Half Day, Full Day
Saugertiesmarina.com 845-246-7533

BOAT REPAIR

Riverview Marine Services Inc.

Complete service center, electrical and mechanical
repair and maintenance, restoration and repower,
DEC licensed antifouling application, accessory
installation, 20 ton lift. Open all year. 518 943-5311.
riverviewmarineservices.com Catskill NY

W * E * L * L * S

FIBERGLASS BOAT REPAIR

Professional Fiberglassing • Blistering Problems •
Gelcoating • All Warranty Work • Restorations
518-598-6794

West Shore Marine

Full Service Facility, Marina
25 ton travel lift, Haulout to 48'
60 yrs combined experienced mechanics
845 236-4486

AMERICAN BOAT RESTORATION

Certified Fiberglass, Gelcoat and Multi-Color Polyflake
Repair • Complete Fiberglass
Refurbishing - Cosmetic & Structural Specialist
Soda Blast Cleaning • Insurance Estimates Mobile
Service Available. • Insured
Over 37 Years Experience.
413.665.7424 • 518.577.7799 email: boatrepair@aol.com
• americanboatrestoration.com

www.constructivehands.com

FUEL DISPENSING REPAIR SERVICES

Fuel Dispensing Repair Services Including Hoses,
Nozzles, Dispensers,
Pumps, Piping, Etc.
Tank monitoring service and repairs, sales and
installation on all equipment.
All forms of maintenance and repair
for fuel dispensing needs.
845-787-3984 • 845-787-3030

Unique Marine Supply & Repair Service Hauling, Storage,

Winterization, Shrinkwrap, Engine Repair,
Repair and Boat Supplies
Call 845-489-4524
Email: Info@Uniquemarineny.com
24 Olympic Way, Poughkeepsie, NY 12603

Richard Terpening's Watercolors Marine

845-340-9854 • 102 1st St., Connelly, NY 12417.
Major & Minor Fiberglass Work • Woodworking &
Bright Work • Detailing & Waxing • Osmotic Blister
Repair • Custom Fabrication and MORE.

ALEX'S MARINE PLUS

MOBILE DOCKSIDE SERVICE - Winterizing •
Tune-Ups • Re-Powers • Electronics • Hauling •
Maintenance • Rt. 9W, New Windsor, NY.
845-565-9199

NICK ROBERTI'S MARINE

835 Flatbush Rd. Kingston, NY 12401
Fully Stocked Marine Store. In-Board/ Out-
Board Re-power Experts.
845-336-8111 • robertiboats.com

FIBERGLASS PLUS

Structural & Cosmetic Repairs
Marine Parts & Accessories
Shrinkwrapping - Detailing - Fully Insured
914-652-8301 * 914-755-1922

ACTION MARINE SERVICES

Mobile Service to Your Location
Spring Tune-Ups & Service
Gas & Diesel Techs, Outdrive Services
Expert Service, Repairs & Repower
25 Years Experience, Fully Insured
actionmarine@optonline.net
Call Guy (845) 721-2146

BOAT TRANSPORTING

S & J MARINE SERVICE

Hydralulic Trailer-Air Ride Fully Insured
Local & Residential Service Sail Boat-
Wide Loads- Serving the Tri-State Area
718 918-2492

ALCOVE CARRIERS, Inc.

Power and Sail transport to 35"
Local And Nationwide.
866 Route 4S, Schuylerville, NY 12871
518-365-5144 email: alcovemarina@aol.com

SAUGERTIES MARINA

Local & Long Distance Fully Insured.
Up to 30' Boats. Complete Service Facilities
Saugertiesmarina.com 845-246-7533

BOAT DELIVERY SERVICE

Capt. Rob Lewis 30 years experience
Call 914 489 4848

NICK ROBERTI'S MARINE

Local & Long Distance
Hydraulic Air Ride Trailer
Licensed and Insured
Kingston, New York 845-336-8111

ENVIRONMENTAL

EcoAssessment, LLC

Environmental Permit Specialists.
NYSDEC and USACE
Dredging, Docks, Bulkheads and Seawalls
Stormwater
Call Tim Judge 845-222-6135.

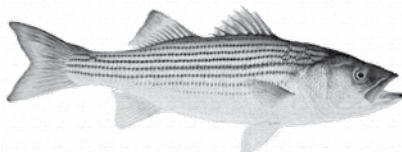

BOAT TRAILERS

GALVANIZED TRAILERS - ALL SIZES

Custom Modifications Available
New & Used - Call For Prices
SEIDEL'S 518 - 537-6060

TRAILERS FOR BOATS

10' - 32' Roller And Bunk Design
All On Sale, Call For Pricing
Nick Roberti's Marine - 845-336-8111

CANVAS / UPHOLSTERY

Guaman Canvas, LLC

Expert Design & Installation
Custom Marine Canvas • Fabricators &
Upholstery • GUAMAN DOES IT ALL!
914-432-7329 • 914-373-0191
Ossining, NY 10562
www.guamancanvasllc.com
email: Guamancanvasllc1@gmail.com

Action Marine Services

Interiors • Exteriors • Vinyls & Canvas •
Custom Canvas Cockpit Covers Foam
Cut-to-Size • Supplies for Do-it-Yourself
Projects • Over 25 yrs Experience
actionmarine@optonline.net
Call Sandi (845) 721-2145

Patino Canvas

Complete Canvas Outfitters
Motorboats • Sailboats • Home
www.PatinoCanvasCorp.com
John Patino 845-429-6146

SEAFARER CANVAS LLC

Custom Canvas Fabricators, Dockside Service
with Slips. Visit our 4000 Sq. ft Showroom
Ossining, NY Telephone 914- 923-3544
www.seafarercanvas.com

www.constructivehands.com

ENGINE REPAIR

Albany Marine

We specialize in repair of 1956 to date
Outboard Engines, Johnson, Evinrude,
Yamaha Outboards and Merc,
OMC, Volvo Sterndrives
Factory Trained, years of experience.
Parts & Accessories
518 434 4421
Albanymarine@TomsAlbanyMarine.com

Certified Marine Service

Gas & Diesel - Service & Sales
Mercury Outboards, Mercruiser Inboards &
Sterndrives. Volvo Penta; Universal;
Yanmar; Westerbeke; Generators
845-339-3060
www.certifiedmarineservice.com

Saugerties Marine

Complete Outboard And Inboard Engine
Repair, Evenrude, Merc, Mariner,
Nissan/Tuhotsu outboards, Merc Cruiser
and Volvo Pinta Outdrives Merc Cruiser
and other manufacturer inboards.
845-246-7533

Mohawk Valley Marine

Factory Certified Warranty
& Repower Center
Outboards-Inboards • Sterndrives
We rebuild and repair them all.
Fuel injector cleaning and repair.
Call 518-399-2719

MARINAS

LOCK 1 MARINA

On the Champlain Canal, secure, tran-
quil surroundings, picnic area, restroom
& shower, easy tie-up, restaurant near-
by, launch ramp and secure parking.
Tel: 518-238-1321
www.lock1marina.com

SAUGERTIES MARINA

Local & Long distance transporting
Boat & Kayak rentals. 24 hour repair & Fuel
Overnight & Seasonal docking 845-246-7533

MARINE DIVING SERVICE

Salvage, Search/Recovery
Propeller service, Underwater cutting,
and more. 914-313-6394

Email: marineservice247@gmail.com
www.marinedivingservice.com

MARINE INSURANCE

KARAS INSURANCE AGENCIES

Power Boats • Sail Boats • Jet Skis
YACHT CLUBS • MARINE DEALERS
321 S. Riverside Ave.,
Croton on Hudson, NY
914-271-5188 fax: 914-271-9390
cathykaras@karasinsurance.com

MARINE SURVEYORS

Al Prisco C.M.S. Marine Surveyor

Consultant - Pre-Purchase, Insurance, Dam-
age Member: SNAME, ABYC, NFPA, Boat-US
Exchange. Specializing in Thermal Imaging.
845-228-1071 • 914-645-3525
www.marinesurveyor.com
email: boatsurvey@yahoo.com

Captain Alan Bartlett, AMS

Marine Surveyor
Member SAMS, ABYC
Tel. 518-859-8660

Coast Marine Services

Insurance-Appraisals-Pre-Purchase
Member ABYC, NFPA, SAMS, IAMI
Captain Guy Falkenheimer, A. M. S.
200 ton licensed Captain
518-784-2181

Oceanis Marine Services Inc

Charlie Gruetzner, AMS Accredited Marine Surveyor
• Pre-Purchase, Insurance, Damage Member: SAMS,
ABYC, HVMTA, IAMI
Tel. 914 737 0253
Charlie@oceanismarine.com
www.oceanismarine.com

OSPREY MARITIME SERVICES Ltd

Instruction Power and Sail • Delivery
• Harbor Tours • Pre-Purchase Advice
• Reasonable • Reliable • Experienced
captjimchambers@aol.com 917-796-9631

Raymond E. Clifford - Surveyor

Clifford Marine Services
Croton-On-Hudson, New York 10520
914-419-7926
rcliff60@yahoo.com

Conroy's Bait Supply

All Kinds of Live Bait

518-273-2582

Open All Year



- Worms
- Minnows
- Crayfish
- Fishing Tackle
- Handguns
- Rifles
- Shotguns
- Ammunition

711 19th Street, Rt.2, Watervliet, NY 12189

ZOLLER'S Marine Center, Inc.

**DISCOUNT MARINE SUPPLIES
BOAT SLIPS FOR SALE OR LEASE**

Prime Boat slips available at Half Moon Bay Marina, Croton-on-Hudson NY. For LEASE (daily, weekly, monthly and seasonally) From 10ft - 100ft plus. Call for availability and pricing. Zoller's Marine Center Inc. 914-271-8803 ask for Mark or Jessica. Two 55Ft Boat Slips Available For Sale At Half Moon Bay Marina. Combined can handle a 100ft plus boat. Call Zollers Marine Center for pricing information 914-271-8803.

Boats for Sale:

2012 23ft Monterey M3 Mercruiser 350 Mag 95 hrs like new. Loaded.\$42,500
 2002 Sea Ray Sundance 240 only 265hrs.....\$22,955.
 1998 4 Winns 278 Vista twin 4.3 Volvo\$17,900.
 2000 4 Winns 298 Vista Twin 5.7 Volvos\$26,500.

Outboards for Sale:

•1982 Johnson 40 hp Commercial, Long Shaft, Manual Start, Excellent Running Condition, Fully Serviced.....\$600.

914-271-8803

87 North Riverside Ave. Croton-on-Hudson, N.Y.

email: markmzmarine@gmail.com

Coeymans Landing Marina 518-756-6111



Brokerage Boats



37' 2008 Larson Day Cruiser	\$129,900.
26' 2007 Regal on dual axle Trailer	\$32,500.
32' 1988 Carver Mariner, twin Merc's, Very Clean	\$22,500
37' 1999 Maxum (800 hrs) Merc 7.4 454 loaded	\$69,000
32' 2005 Sea Ray 320 SD Merc twin 300Hp 277Hrs Loaded	\$79,000
34' 1987 Silverton Convertible 34 T/Crusade Air/Heat full bimini	\$22,000
30' 2003 Bayliner 305 twin 220Hp arch with full enclosure air/heat	\$36,500

www.coeymanslandingmarina.com

**WE NEED YOUR
BOAT TO SELL**
Now is the time to

list your boat
with Coeymans
Landing Marina

Call Kim at
518-756-6111

All Boats Located in Our Yard,
Coeymans, NY

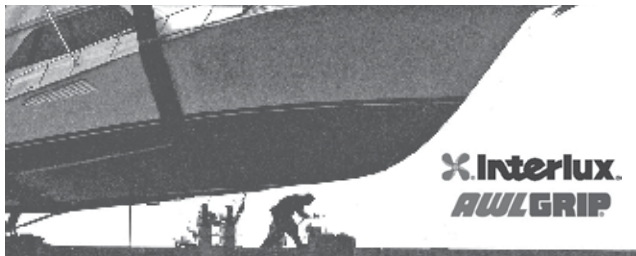

Interlux
AWLGRIP

Richard Terpening's
WATERCOLORS MARINE

- Major & Minor Fiberglass Work
- Woodworking and bright work
- Detailing and waxing
- Osmotic Blister Repair
- Awl Grip Painting
- Gel-Coat Repair
- Barrier Coating
- Interior, Exterior Wood Repair
- Custom Fabrication & Modification
- Swim Platforms, Pulpits...more

Offering
Mobile Service
from Westchester
to Lake George
Free Estimates
15 Years
Experience

"Ask about our Winter Shrink Wrap Specials"

845-340-9854 cell 845-416-3531

102 1st. Street, Connelly, NY 12417
Located at Rondout Yacht Basin

Macdonald Marine
Preowned Boats

22' 2017 Glastron GTS 225 - US\$50,5000

24' 1995 Aqua Patio - US\$7,500

22' 2017 Glastron GTS 225 - US\$50,500

21' 2007 Stingray 210 LR - US\$16,000

18' 2002 Stingray 180 LS/LX - US\$6,500

www.macdonaldmarineny.net

1 Marina Drive, Mahopac, NY 10541 845-628-2333



THE HUDSON VALLEY'S
**ONLY PROTECTED
COVE MARINA**
A FULL SERVICE MARINA
CALL TODAY 845.473.8283

HYDE PARK MARINA IS LOCATED BETWEEN POUGHKEEPSIE AND HYDE PARK,
JUST 75 MILES NORTH OF NYC AND 75 MILES SOUTH OF ALBANY.

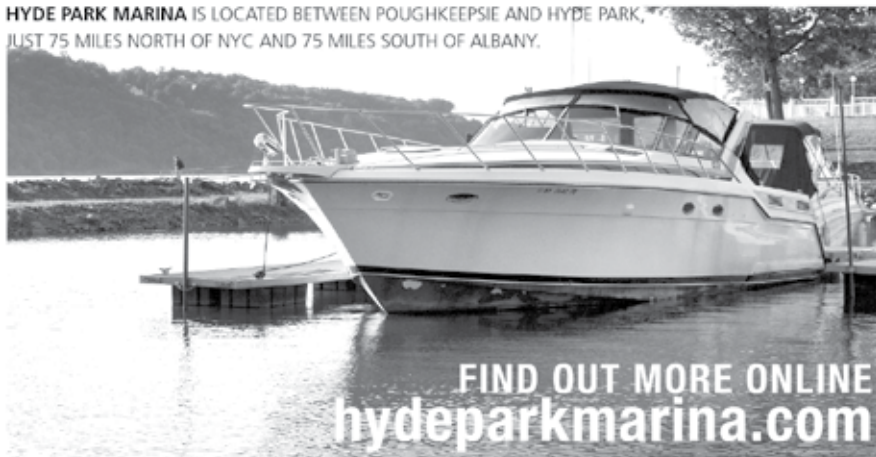

FIND OUT MORE ONLINE
hydeparkmarina.com

**HYDE PARK
MARINA**

- Transients Welcome
- STRIPER FISHERMEN
Season Slip Rental &
Temporary Boat Docking
For Striper Fishing
- Convenient to Trains
and Airport

**ENJOY
YOUR
SUMMER!**



HYDE PARK MARINA IS
CONVENIENT TO
WALKWAY OVER THE HUDSON,
CULINARY INSTITUTE OF AMERICA &
MANY GREAT HISTORIC MANSIONS

Nick Roberti's Marine

In-Stock BOAT TRAILERS

845-336-8111
robertiboats.com
835 Flatbush Road
Kingston NY, 12401

**LARGEST MARINE
STORE AROUND**



**HUGE In-Stock
PARTS
Inventory
Knowledgeable
Friendly Staff**



**Factory Trained
certified service
experts for Mercury,
Evinrude, Yamaha
Outboards &
Mercruiser, Volvo
Penta Sterndrives.**

**RE-POWER EXPERTS
INBOARDS & OUTBOARDS**

**ALL IN STOCK
OUTBOARDS
BELOW
DEALER COST**



Large Selection!
Interlux.

**Best Prices
Anywhere!**



**Yamaha O/B
Trailers
Jon Boats
Fish & Ski
Polar Kraft
Crestliner**



WHITE'S

HUDSON RIVER MARINA

NEW HAMBERG, NY 12590



- Engine & Outdrive Service
- Shaft, Strut & Prop Service
- 25 Ton Open-End Lift
- Launch Ramp
- Gas/Diesel
- Pump-Out



A FULL SERVICE MARINA

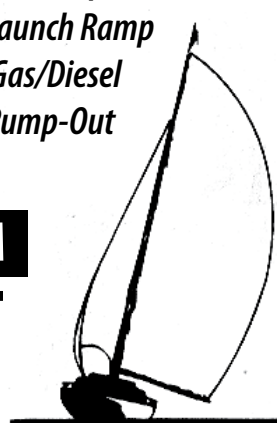

845-297-8520

CLEARANCE PRICES ON ALL MERCURY OUTBOARDS

5 MILES SOUTH OF POUGHKEEPSIE ON THE HUDSON RIVER

Boat Delivery Service



Capt. Rob Lewis

- Hydraulic AirRide Trailer (up to 33 feet)
- Fully Insured
- Sailboats & Motorboats

914 489 4848



24-7

- SALVAGE
- PROPELLER SERVICE
- SEARCH / RECOVERY
- UNDER WATER CUTTING AND MORE...

Zidnek
marineservice247@gmail.com

914-313-6394

WWW.MARINEDIVINGSERVICE.COM

LET YOUR BOAT START PAYING YOU BACK GET YOUR CAPTAINS LICENSE TODAY!



Online & Classroom courses available
For More Information, Call
1-800-237-8663 or **516-974-1666**
or log on to
www.seaschool.com

SEASCHOOL
Serving mariners since 1977

For a complete class schedule call
1-800-BEST-ONE (237-8663)
[facebook.com/seaschool](https://www.facebook.com/seaschool)
twitter.com/seaschoolonline



30+ Years of Excellent Service

Marine Fabrication for Power & Sail

**CUSTOM
CANVAS**



**CUSTOM
INTERIORS**



**EXTERIOR
UPHOLSTERY**



**REPAIR
SERVICE**

NY Location

@Westerly Marina
7 Westerly Road
Ossining, NY 10562

914.923.3544

www.seafarercanvas.com

CT Location

@Norwalk Cove Marina
45 Calf Pasture Beach Road
Norwalk, CT 06855

203.939.1872

HUDSON RIVER PILOTS ASSOCIATION



**GUIDING SHIPS
THAT ENTER THE HUDSON RIVER
SAFELY SINCE 1958**

(BOTH STATE & FEDERALLY LICENSED PILOTS)

(718) 815-4316 | HUDSONRIVERPILOTS.COM
201 EDGEWATER STREET | STATEN ISLAND, NY 10305

Jo-Lea
AUTOMOTIVE CENTER

Established in 1960, Jo-Lea Auto Center is a family owned business. Our well trained employees strive to provide each job with the utmost superior service possible. Jo-Lea has a long standing dedication to provide quality products and customer service. Whether it is an oil change, routine maintenance, inspection, headliner, antique car restoration, commercial seating or marine restoration that you entrust us with, rest assured your job will be treated with the accuracy and precision that it so deserves. Call us or stop in today. You will not be disappointed.



SERVICES INCLUDE:

- NYS Inspections
- Oil Changes
- Scheduled Maintenance
- Brakes
- Timing Belts
- Convertible Tops
- Boat Seats/Covers
- Interior Restoration
- Mechanical Restoration
- Custom Upholstery

OUR HOURS:

Monday - Friday
8:00 am - 5:00 pm

Saturday
8:00 am - 12:00 pm

(914) 739-2955 • 1600 MAIN ST, PEEKSKILL, NY 10566 • JO-LEAAUTO.COM

BOATS FOR SALE



1988 Silverton 34C, Mint Condition, twin 350/270 Crusaders engines, Starboard engine replaced last week (Vortex). New engine has a three yr. warranty, Current owner for past 15 yrs., Includes windlass, stove, microwave, GPS, AC, Gen, sleeps 6, Brand New Atlantic Tower, Can be seen at Half Moon Bay Marina, Call 914-382-2505 \$25,000 OBO. 7



1992 CARVER 3350 Aft Cabin Motor Yacht
Twin 7.4 340 HP Crusaders, Generator, 2 zone AC/Heat Radar, Chart Plotter, GPS, Full Bridge and AFT deck canvas. 2 Staterooms, 2 heads, includes separate stall shower in Master Suite. Dinette, Full size Refrigerator. Many extras and updates available upon request. Excellent Condition - meticulously maintained. 7
\$45,500 Port Ewen, NY (Kingston area)
Contact John (845-229-8305) or jlfalabella@optonline.net



41' Hatteras Double Cabin - 1969 Twin Detroit 8V53 - Diesel-8KW Onan Generator Installed 1991, Windlass, Radar, Digital Reverse Cycle A/C & Heat. New Digital Inverter System-Wet Bar with Ice Maker-14' Beam, Located on Rondout Creek, Kingston, NY \$65K- 845-453-1424. 9



1992, 30' 300 Sundancer. Twin 5.0 L engines, new port engine and new risers, Radar, GPS, A/C reverse cycle heating/cooling and Generator. Hudson River, . (2) Two VHF radios, Microwave, Electric/Alcohol stove top, AC/DC Refrigerator, Battery charger, Flat panel TV, Stereo system with cabin and cockpit speakers. Search light at bow, Anchor windlass. New full enclosure canvas. Located at Whites Hudson River Marina, New Hamburg, NY. \$25,000. Call: 845-551-2255 7



1969 Pettibone 70 MK Rough Terrain Crane.

Ideal for marina, boat yard or construction. Recently refurbished. Rebuilt engine, charging system and front outriggers. 35 ton capacity. Asking \$15,000 Exceptional value! Contact: Croton Yacht Club: leveyjim6@gmail.com



2000 Hydrasports Center Console Located In Newburgh, NY 150 Hp Johnson Outboard, Power Tilt/Trim, Stainless Steel Prop, Vhf Radio, Gps/Fishfinder/Chartplotter, Canvass T-Top, Porta Potty, Marine Battery Charger, Trim Tabs, New Bottom Paint. Incl: Alum. Tandem Trailer, New Stainless Steel Disc Brakes. Ready To Fish \$14,500. Call Charlie 914-474-7766 9



2003 - 298 Vista Four Winns - \$49,000 5.0 GX Volvo Twin engines - 270 HP each approx. 350-400 hours. 31' includes swim platform and ladder, full head, 2 sleep compartments, kitchen, and seating area, sits approx. 8-10 people on deck, including helm. New GPS Garmin, Stereo Kenwood with Bluetooth, new alternators (2017), bellows + gimbal bearings (2015), bottom of boat is painted even though docked in fresh water. Heat + AC, Generator 5Kw (70 hours). Full canvas camper, ropes, fenders, life jackets all included. Windlass, Remote Spotlight, more. Call Bob 845-661-9185



32-foot Grand Banks, 1980 Sedan, very good condition, documented, systems meticulously maintained. Ford Lehman 120/2,411 hours, bow thruster, AC-heat, stateroom, shower/head. Death in the family, must sell. \$62,000, Catskill, NY. Mark 914-388-0523 or eboat2@gmail.com. 8

BOATING on the HUDSON CLASSIFIEDS

35 words for 3 months - \$35.
with B+W photo - \$175.
with color photo - \$205.

email: vargojhvargo@aol.com



2001 Bayliner 2850 Ciera 454 HP single engine w/Bravo3, Sleeps 6, AC/Heat, Full galley/Head,, Microwave, TV/Cable hook up, New Risers & Manifolds/Batteries, Low hours, Excellent condition in & Out & Canvas. Cleanest boat I have ever seen \$24,500 By Owner 914 906-2853 8



2008 25' Ranger Tug, Commissioned 2010. Freshwater vessel. Yanmar diesel and pump impeller serviced, Garmin electronics. Galley, 110/12 V fridge, trailer, lines, fenders, spare parts, bottom paint, hull waxed and interior cleaned. \$110,000. Call Ron - 518-696-4547



1997 34' Mainship Motor Yacht. Twin 454 EFI Marine Power 658 hours. Radar, Sonar, Color GPS, Auto Pilot, VHF, Windlass, 2AC's Generator, 3 TV's, New Canvas & Isenglass, 2 Heads w>Showers, 2 PrivSt rms. Call Bob (H)201-791-0120 (C)201-741-0007 \$85,000 Can be seen at Haverstraw Marina. 8

MACDONALD MARINE INC

SUMMER

IS HERE!

Located on beautiful
Lake Mahopac

Phone

845.628.2333

Web/Email

MACDONALDMARINE.NY.COM
MACDONALDMARINE@VERIZON.NET

Address

1 MARINA DR
MAHOPAC, NY 10541



Manitou



GLASTRON



GTS 225 SHOWROOM SPECIAL 2017

SAIL BOATS

1968 Cheoy Lee, 36' Ralph Luders fiber glass design, 26 hp Westerbeke, last on water 10/16, intact and all there, some TLC, taking offers Must Go Eric 518-703-5148 eborfitz@gmail.com 8

1986 - Caliber Yacht - Tri Cabin Motivated To Sell --- \$14,000 - 28 Ft. - Yanmar 16 Hp Diesel- Many Amenities - Inflatable W/Motor - Located Chelsea, Ny - Call Jim 845-562-9067.

HELP WANTED

Chelsea Yacht Club is seeking qualified/eligible persons to skipper the Club's Launch during the 2018 Season, April to October. For additional information, email: CYC1881@optimum.net or call 845-831-7245. Please include any applicable experience.

\$79.99 buys a Gallon of Ablative Anti-Fouling paint.

J. J. Burck's Boat Store,
526 City Island Ave. Bronx, NY
718-885-1558



1987 Sea Ray 270 Amberjack, twin MerCruiser 4.3L V6 engines with alpha drives. Delivers 410 total HP and cruises at 24 knots to a max of 32. Upgrades include an aluminum hard top with pole holders, remote spotlight, and deck lights: full umbrella front, side and rear panels; two new Larson high back recliner Captains Chairs with matching umbrella covers; re-upholstered cockpit side and rear panels; new Lewmar V700 windlass; icom VHF IC-M59 radio and a Garmin Echo 300c color fish finder. Asking \$10,900. For more pictures see Craigslist Hudson Valley. Call 914-475-4847. 9

Eastern NY Marine Trades Association



ADIRONDACK MARINE
3226 Lakeshore Dr.
Lake George, NY 12845
Nautiques by Correct Craft,
PCM Engines.
518-668-2658 Fax 668-4143
www.adirondackmarine.net
drew@adirondackmarine.net

ALPIN HAUS MARINE
4850 State Hwy 30
Amsterdam, NY 12010
518-843-4400
sarminio@alpinhaus.com
www.alpinhaus.com

ANDERSEN MARINE
Boat Transport
883 Route 50
Burnt Hills, NY 12027
518-399-5003
www.andersonboat.com

BECKLEYS MARINA & COTTAGES 107 Lake Shore Dr
Diamond Point, NY 12824
518 668-2651
www.beckleysboats.com

BLAIN S BAY MARINA
221 Dunsbach Ferry Road
Cohoes, NY 12047
518-785-6785
Blainsbaymarina.com/marina@
JimNichols@aol.com

BEACON PUBLISHING
DBA Boating on the Hudson
and Beyond
PO Box 627
Verplanck, NY 10596
845-401-2699

BOATS BY GEORGE
18 State Hwy 149
Lake George, NY 12845
Cobalt Four Winns
Marker One
518-793-5452
Fax 518-793-5481
www.boatsbygeorge.com
george@boatsbygeorge.com

CANADA LAKE STORE & MARINE 103 Old State Road
Caroga Lake NY 12032
Moomba Four Winns
Misty Harbor
518-835-6069
www.canadalakemarine.com
clstore@telenet.net

CAPITAL DISTRICT MARINE
17 Jackson Ave
Cohoes, NY 12047
518-237-3442 Fax-237-1840
www.capitaldistrictmarina.com sales@
capitaldistrict.com

CASTAWAY MARINA
2546 Route 9L
Queensbury, NY 12804
Regal • Mastercraft
Premier Pontoon Boats
518-656-3636 Fax-656-3692 www.
castawaymarina.com Thalia@
castawaymarina.com

CHIC'S MARINE
PO Box 1237
Bolton Landing, NY 12814
518-644-2170
Whaler, Yamaha Waverunners www.
chicsmarina.com

COVE MARINA & PUB
886 Rte 4 South
Schuylerville, NY 12871
518-695-6079
alcovemarine@aol.com
FAX: 518-695-9268

CR'S MARINE SERVICE
2103 Christer Avenue Schenectady,
NY 12303.
Angler, Checkmate,
Mirro Craft, Bass Cat
518-370-3596
www.crsmarine.com info@crsmarine.
com

E-Z MARINE & STORAGE, INC
POB 375 II Town Shed RD
Brant Lake, NY 12815
(518)494-7381 phone
(518)494-3054 fax
www.ezmarineandstorage.com
info@ezmarineandstorage.com

ELITE DOCK COMPANY
84 Barthel Lane
Queensbury, NY 12804
518-656-3625
www.elitedocks.com
info@elitedocks.com

F.R. SMITH & SONS
Sagamore Rd. POB 87
Bolton Landing, NY 12814
Bryant Old Town Canoes
518-644-5181 Fax-644-2988
www.frsmithandsonmarina.com
scott@frsmithandsonmarina.com

F.R. SMITH & SONS
Sagamore Rd. POB 87
Bolton Landing, NY 12814
Bryant Old Town Canoes
518-644-5181 Fax-644-2988
www.frsmithandsonmarina.com
scott@frsmithandsonmarina.com

FREEDOM BOAT CLUB
LAKE GEORGE
3960 Lake Shore Drive
Diamond Point, NY 12824
518-846-0201

HMS AGENCY INC.
950 New Loudon Road
Latham, NY 12110
518 690 0360
bmathers@hmsagency.com

HYDE'S BOATS & RV
64 Blue Barn Rd
Rexford, NY 12148
Qwest, Skeeter, Bass Boats,
G3 Aluminum, Fishing Boats

KARNER DOCKS & LIFTS
123 Rifle Range Rd
Albany, NY 12205
518-281-6080
www.karnerdocks.com
karner18@aol.com

KELLOGG MARINE SUPPLY
10 Doggetts Coat Pl
Saratoga Springs, NY 12866
518-441-7475
dcains@kelloggmarine.com

KNAPIK'S MARINE
197 Forest Ave.
Amsterdam, NY 12010
Smoker Craft
www.knapiksmarine.com
info@knapiksmarine.com

LOON LAKE MARINA
47 Marina Rd.
Chestertown, NY 12817
Sylvan, Sun Chaser, Heritage Kayaks
518-494-3410
www.loonlakemarine.com
rich@loonlakemarine.com

MORGAN RECREATIONAL SUPPLY
800-836-5300
FAX: 888-353-8099
av4372@hotmail.com

MOHAWK VALLEY MARINE
47 Mohawk Avenue
Alplaus, NY 12008
Starcraft
518-399-2719 fax 518-384-0068 www.
mohawkvalleymarine.com boats@
mohawkvalleymarine.com

PILOT KNOB MARINA
1881 Pilot Knob Rd.
Kattskill Bay, NY 12844
Chaparral
518-656-9211 Fax-656-3023 info@
pilotknob.com

MOUNTAIN MOTORS & RESTORATION
9663 Graphite Mountain Rd.
Hague, NY 12836
518-586-2502
www.mtnmotors.com
mtnmotorsrestore@gmail.com

POINT BREEZE MARINA
1459 Rt 9P
Saratoga Springs, NY 12866
Glastron, Ebbtide, Azure, Crestliner
Bennington Pontoon,
Sedona Pontoon
518-587-3397 fax 518-581-8000
www.pointbreezemarina.com
ptbreezemarina@aol.com

BOATWORKS MARINE
768 Saratoga Rd
Burnt Hills, NY 12027
(518)584-2628
www.boatworksmarine.com
gm@champlainboatworks.com

THE CHAMBER OF SOUTHERN SARATOGA COUNTY
15 Park Ave. Suite 7 (Behind Shoppers
World Plaza) Clifton Park
Phone: (518) 371-7748
Fax: (518) 371-5025
info@southern-saratoga.org
Office Hours - 8 AM - 5 PM Monday -
Friday Pete Bardunias
pete@southern-saratoga.org

SHORELINE BOAT SALES
21 Sewell St.
Lake George, NY 12845
Chris Craft, Formula
518-668-3297 Fax-668-0484
www.shorelineboatsales.com
mail@shorelineboatsales.com

SCHROON LAKE MARINA
31 Marina Rd.
Schroon Lake, NY 12870
Starcraft
www.schroonlakemarina.com
craig@schroonlakemarina.
com
518-532-7884

SMITH BOYS
1011 State Rte. 9
Queensbury, NY 12804
518-955-2700
www.smithboys.com
rippel@smithboys.com

SNUG HARBOR MARINA
92 Black Point Rd
Ticonderoga, NY 12883
Sting Ray
518-585-2628 Fax 585-9204
www.snugharbormarinainc.
com info@
snugharbormarinainc.com

SMOOTH WATER SPORTS
770 Old Saratoga Rd.
Gansevoort, NY 12831
518-793-5808 Fax 793-5264
www.smoothwatersports.com
info@smoothwatersports.com
Malibu

YANKEE BOATING CENTER
3578 Route 9N
Lake George, NY 12845
Lund, Monterey
518-668-2862 Fax-668-3899
www.yankeeboat.com
jon@yankeeboat.com
Key West, Harris Flotebote
Duranautic
518-377-2376
Fax 518-668-3899
www.yankeeboat.com
jon@yankeeboat.com

ADVERTISER'S INDEX

Glossy Color Pages

- Coeymans
- Corning Glass Musuem
- Erie Canal
- Fresh-Water-Boats
- Hager's Real Estate
- Lake George Steamboat
- Lake Mountain Real Estate
- Liberty Landing
- Mahopac Marina
- OasisTappanZee
- Parks NY
- Pier 701
- Minisceongo Yacht Club
- Riverfront
- Scarano
- Shady Harbor
- Tarrytown Marina
- USA Marina
- Hudson Water Club

Albany Yacht Club	59
Alex's Marine Service.....	2
American Boat Restoration (Dr Gel)	40
Boathouse Restaurant	28
Coeyman's	21
Coeyman's Brokerage.....	62
Conroy's	62
Hagar's	31
Half Moon Bay Marina	72
Hudson Boat Service	13
Hudson GMC -- hudsonpontiac.com	57
Hudson River Pilots Association	66
Hyde Park Marina	63
JoLea Repair	66
Jumpin' Jacks	31
Karas Insurance.....	41
Lou's Boat Basin	58
MacDonald Marine.....	69
Marine Diving	65
Newburgh Yacht Club	50
Nick Roberti	15
Panco Petroleum	50
Precision Propeller.....	58
PT Surplus.....	59
Riverview Marine Services	1
Rob Lewis.....	65
Rondout Yacht Basin	18
Seafarer Canvas	65
Sea Tow	11
Sea School	67
Stewarts	24
Unique Marine.....	2
Viking Boat Yard	1
Watercolors	63
Westerly Marine	41,59
Whites Marina	64
Zollers.....	62

Boating on the Hudson & Beyond is published by Beacon Publishing Corp. Verplanck, N.Y.
 Proud member of the Eastern New York Marine Trades Association, Seaplane Pilots Association, Southern Saratoga Chamber Of Commerce, Experimental Aircraft Association, AOPA, Hudson River Fishermans Association (Awarded Friend Of Hudson River 2015), Hudson River Ice Yacht Club, (Commodore 1973)

Telephone: 845-401-2699
 email: vargojhvargo@aol.com

Publisher & Editor
John H. Vargo

Author, Patent Holder, Speaker, Strong Advocate For Promoting The Marvelously Clean and Bountiful Hudson River.
 WE Must Stop Condemning The Hudson River For Political and Bureaucratic gain!
 Evelyn Augusto, Director of Advertising
 Ms. Merna Popper, Special Projects

Contributing Editors and Writers
 Pete Bardunias
 Ralph Ferrusi
 Lex Filipowski
 Cathy Karas
 John H. Pagliuca
 Al Rudolf
 Jeff Sublett
 Dave and Dee Weakley

Art Department

Design & Layout - Ed Radford
 Graphic Artist & Design • Rich Maffei

©2018 Beacon Publishing Corporation. All rights reserved. Reproduction in whole or in part, by any means, is prohibited without prior written permission from the publisher. The articles submitted by our contributing writers do not necessarily reflect the opinions of the publication.
 Marylou Tortorello, Inc. Bookkeeping & Accounting Service
 2 Depot Plaza, Bedford Hills, NY 10507
 Boating on the Hudson is a registered trademark of Beacon Publishing Corporation.
PLEASE BE AWARE: Much of the information contained herein is of a general nature and should not be considered "The last word". For instance, water depths, tides, launching areas, are in a constant state of change. Caution and common sense are the best attributes when enjoying the many benefits of the Hudson River, its shore line and other areas of the Hudson Valley.
 Printed by Turley Publications, Inc.



HALF MOON BAY MARINA

Croton-on-Hudson, NY

914-271-5400

www.halfmoonbaymarina.com

WIDE SLIPS - DEEP WATER

- Serene, Elegant Setting
- FREE WIFI & Direct TV
- Deep Water Slips
- Mechanics Available
- Floating Docks
- Express Trains To Nyc
- Close To Many Restaurants, Waterfront Walk / Bike Path
- 24 Hour Security
- Secure, Well Lit Parking
- Pump Out / Ice
- Tiled Restrooms & Showers
- Slips From 25' To 145'
- RESIDENT DIVER

EASY ACCESS to
CROTON HARMON
STATION NEARBY

Transient
& Season
Slips
Available

SAFE! CONVENIENT! HASSLE-FREE!

DOCKMINIUMS AVAILABLE.
Westchester's Finest Marina on the Hudson

Opening Day Ceremony of the GlassBarge, May 17, Brooklyn, NY
Don't miss this fantastic show, FREE when it comes to your Hudson River Town.





TARRYTOWN BOAT & YACHT CLUB

Westchester's gateway to the Hudson River

CALM WATER FUELING •  SHELL GAS & DIESEL • FREE PUMP-OUT • TRANSIENT DOCKS
WALKING DISTANCE TO HISTORIC TARRYTOWN/SLEEPY HOLLOW
MUSIC HALL, SHOPS, RESTAURANTS • METRO NORTH RAILROAD TO NYC

ALL NEW FUEL STATION

- ALL NEW PUMP-OUT
- NEW GENERATOR
- NEW FUEL PUMPS
- AUTOMATED CREDIT CARD SYSTEM
- KAYAKS & PWCS
- WAVERUNNERS WELCOME

SPECIAL COMBINATION RATES
FOR YOUR BOAT AND PWCS.
MEMBERSHIP REQUIRED

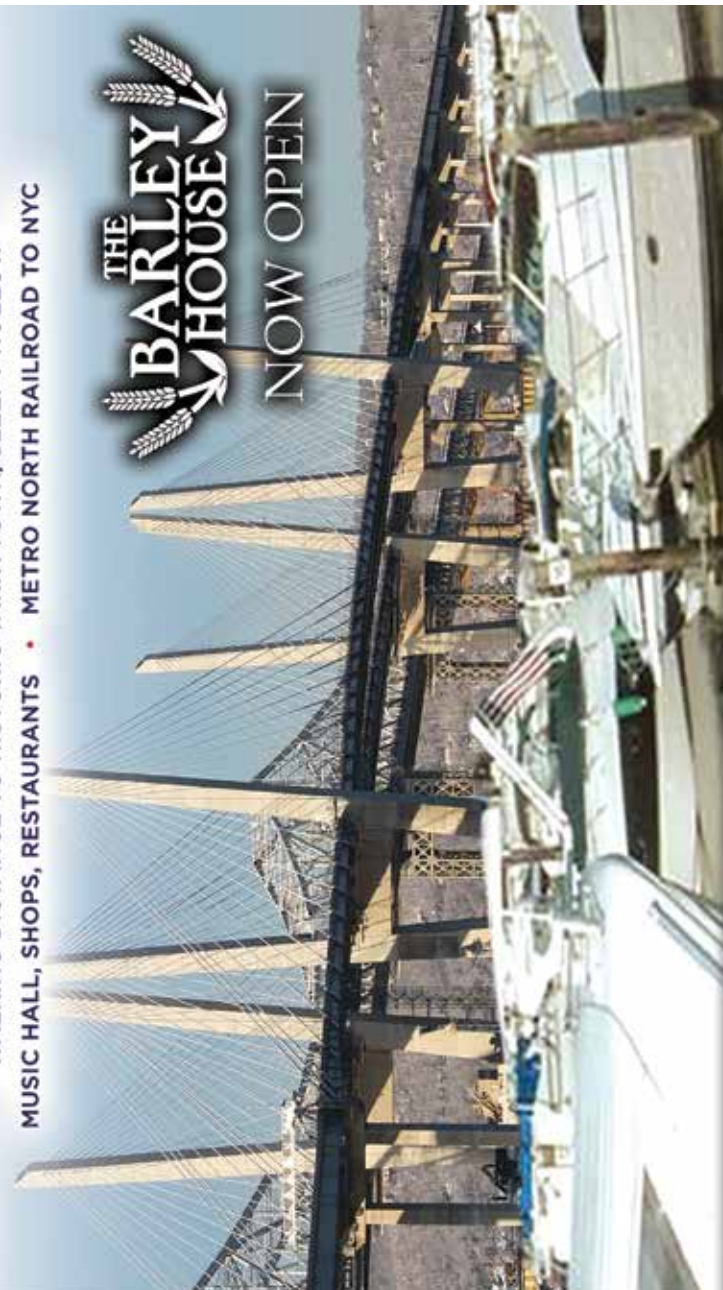

EASTERN SHORE JUST NORTH OF THE NEW TAPPAN ZEE BRIDGE
914.631.1300 | WWW.TARRYTOWNBOATCLUB.COM